

Interleave Division Multiple Access (IDMA)

Lihai Liu, Raymond Leung and Li Ping
Department of Electronic and Engineering
City University of Hong Kong

Outline

- Introduction
- Iterative detection
- Performance evaluation
- Multi-user gain in fading channels
- Other applications
- Conclusions

Outline

- Introduction
- Iterative detection
- Performance evaluation
- Multi-user gain in fading channels
- Other applications
- Conclusions

Features of IDMA

- low receiver cost
- de-centralized (i.e., asynchronous) control,
- simple treatment of ISI,
- cross-cell interference mitigation,
- diversity against fading,
- high power efficiency
- high spectral efficiency
- suitable for wide or narrow band transmission
- flexible rate adaptation

MAC Capacity (per Dimension)

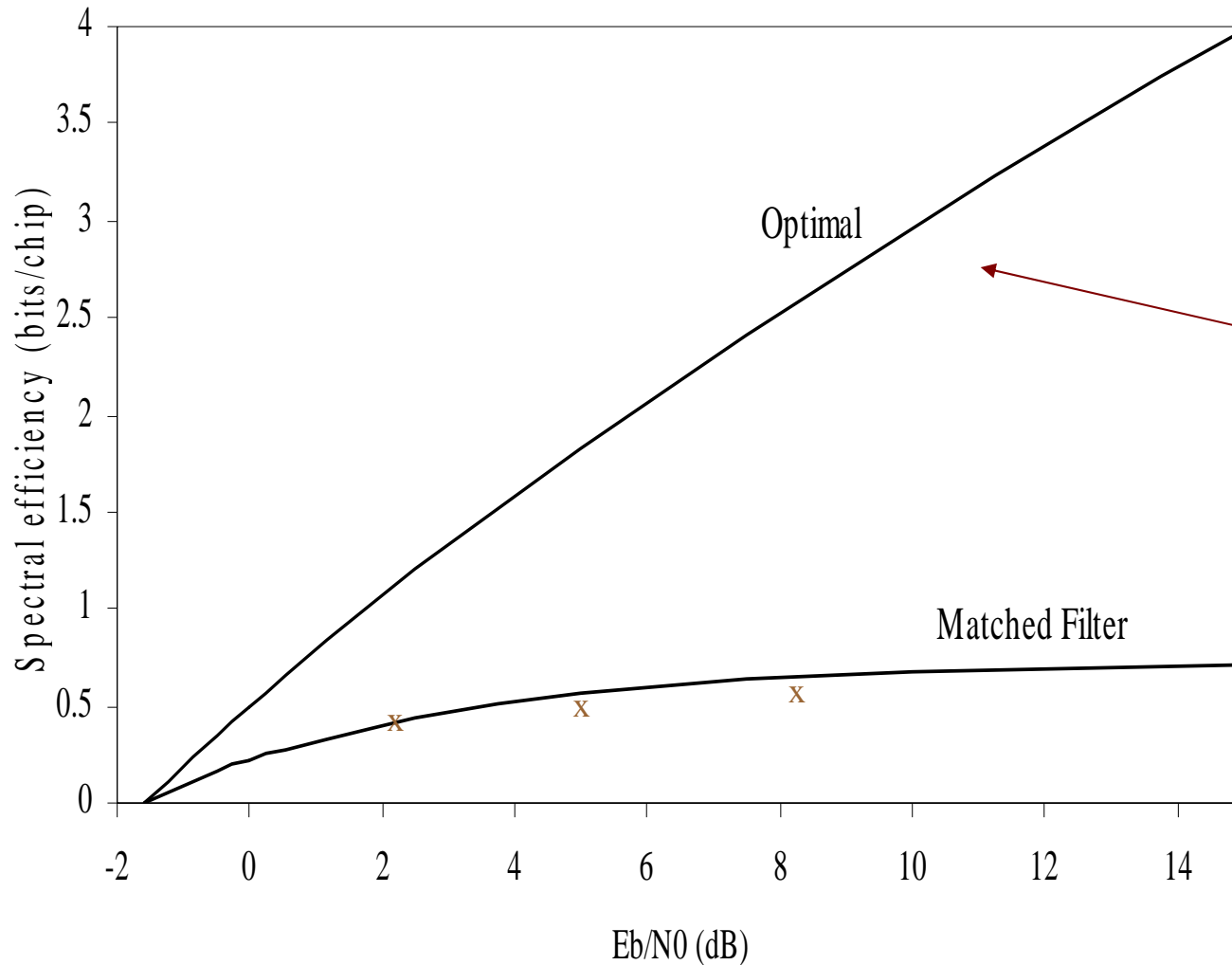

Multi-user detection is necessary to get into this range.

IDMA System Model

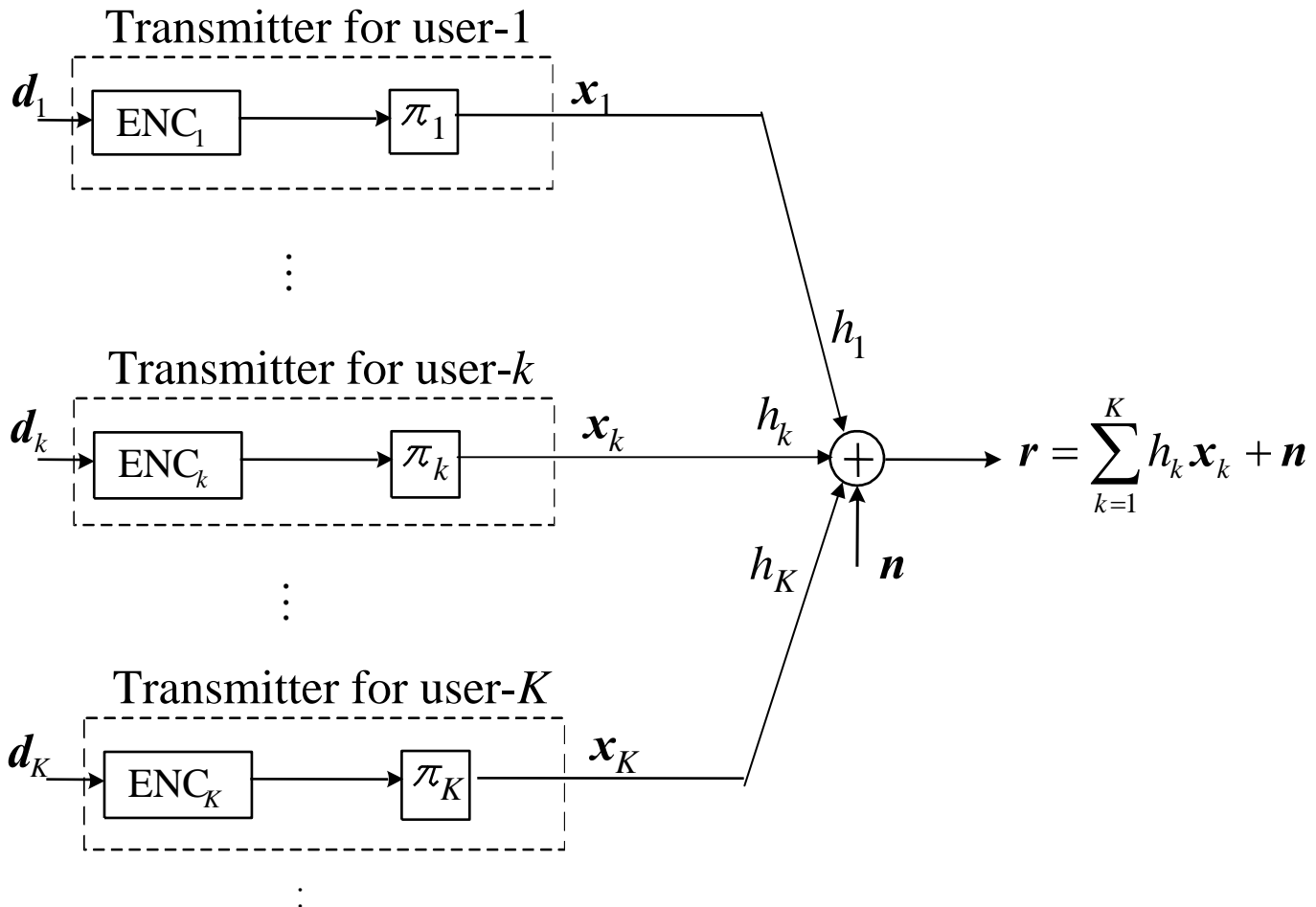

Lihai Liu, Jun Tong, and Li Ping, "Analysis and Optimization of CDMA Systems with Chip-Level Interleavers," *IEEE J. Select. Areas Commun.* vol. 24, no. 1, pp. 141-150, Jan. 2006.

CDMA System Model

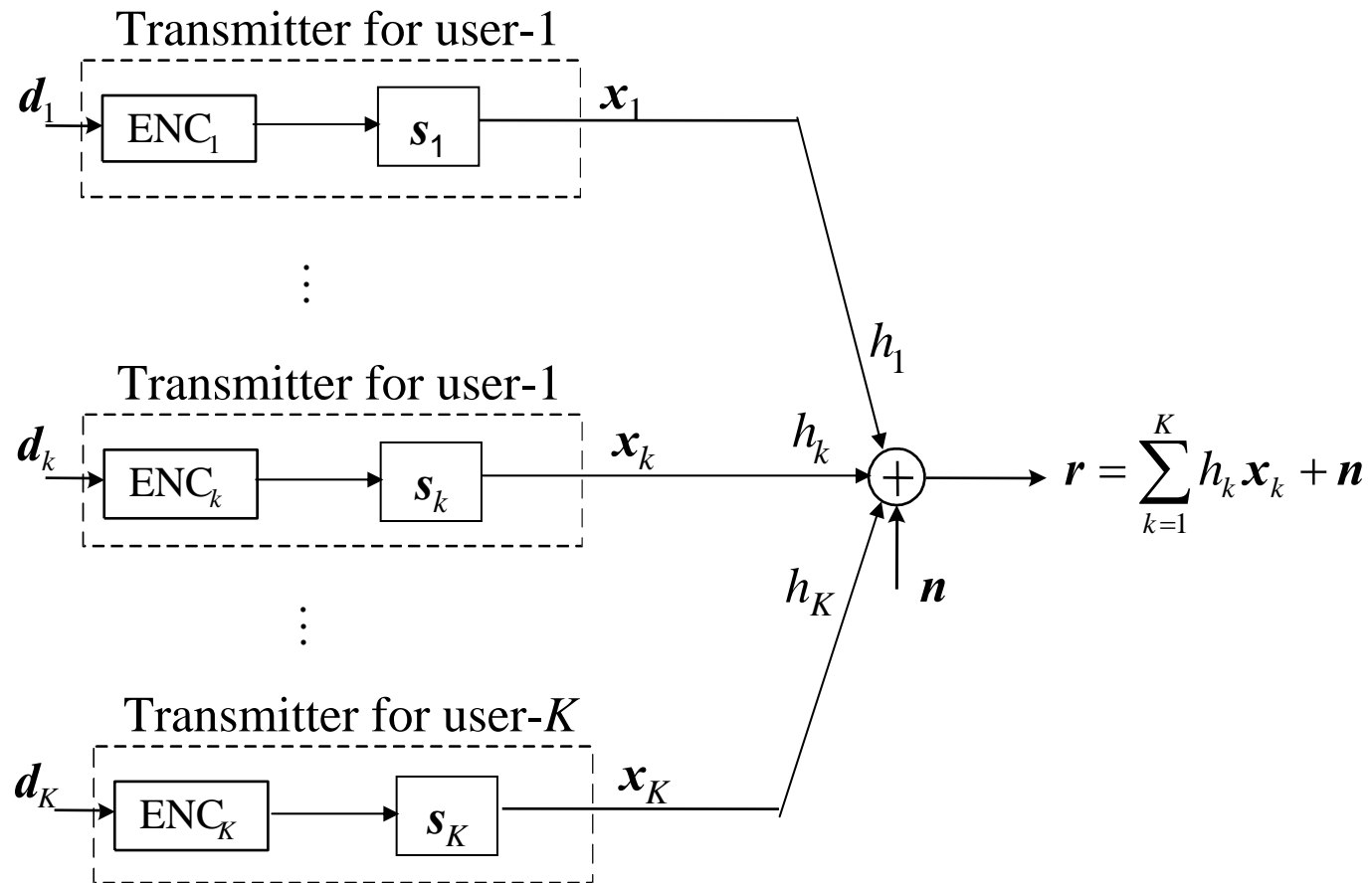

Comparison of IDMA and CDMA

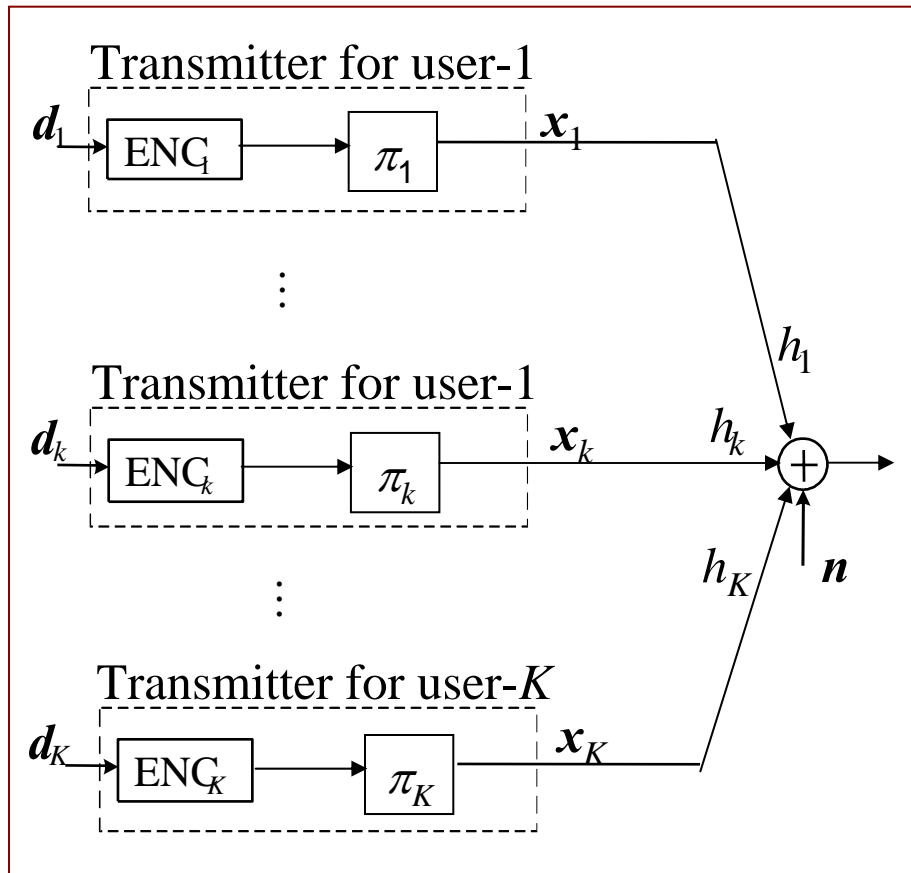

IDMA

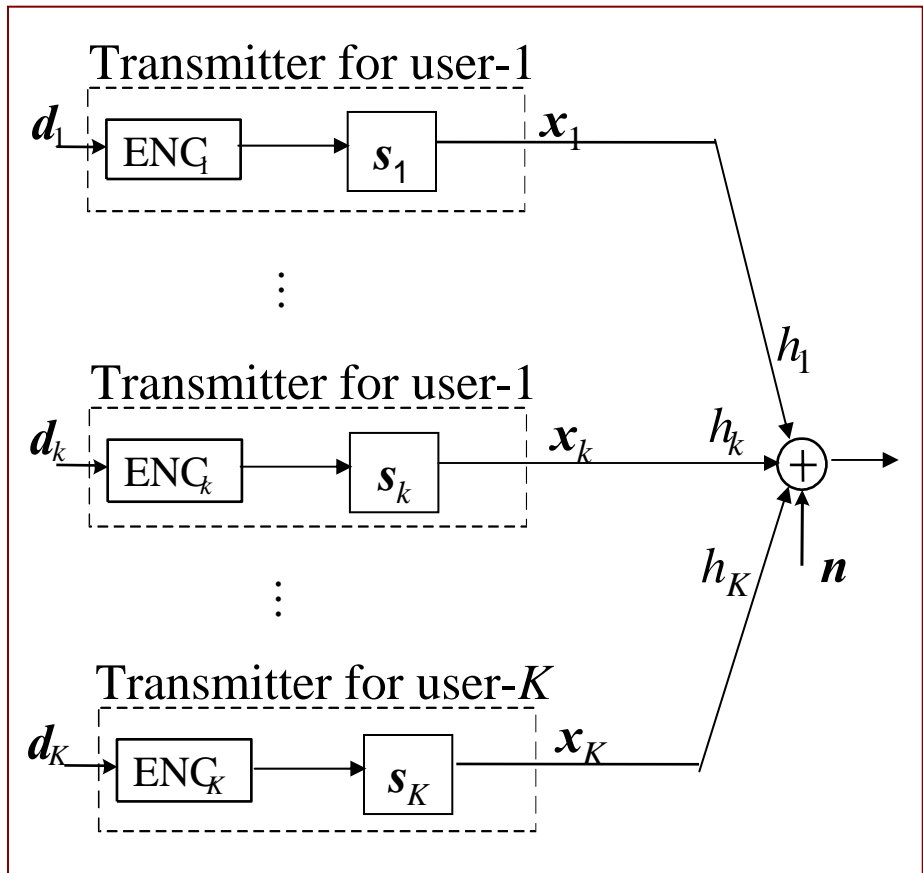

CDMA

A Factor Graph for a LDPC Code

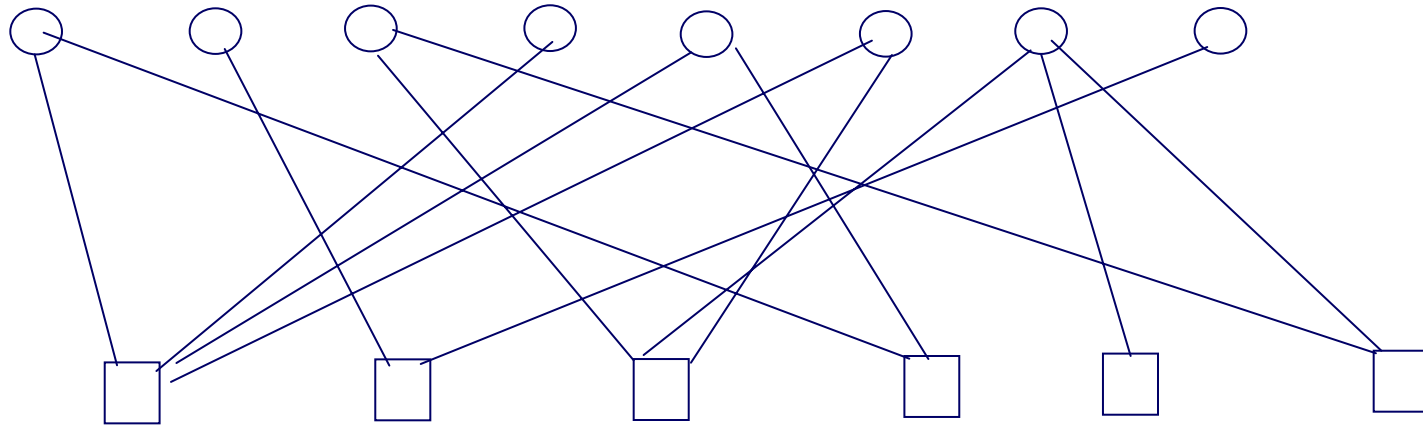

A Factor Graph for a CDMA System

User 1 information bits

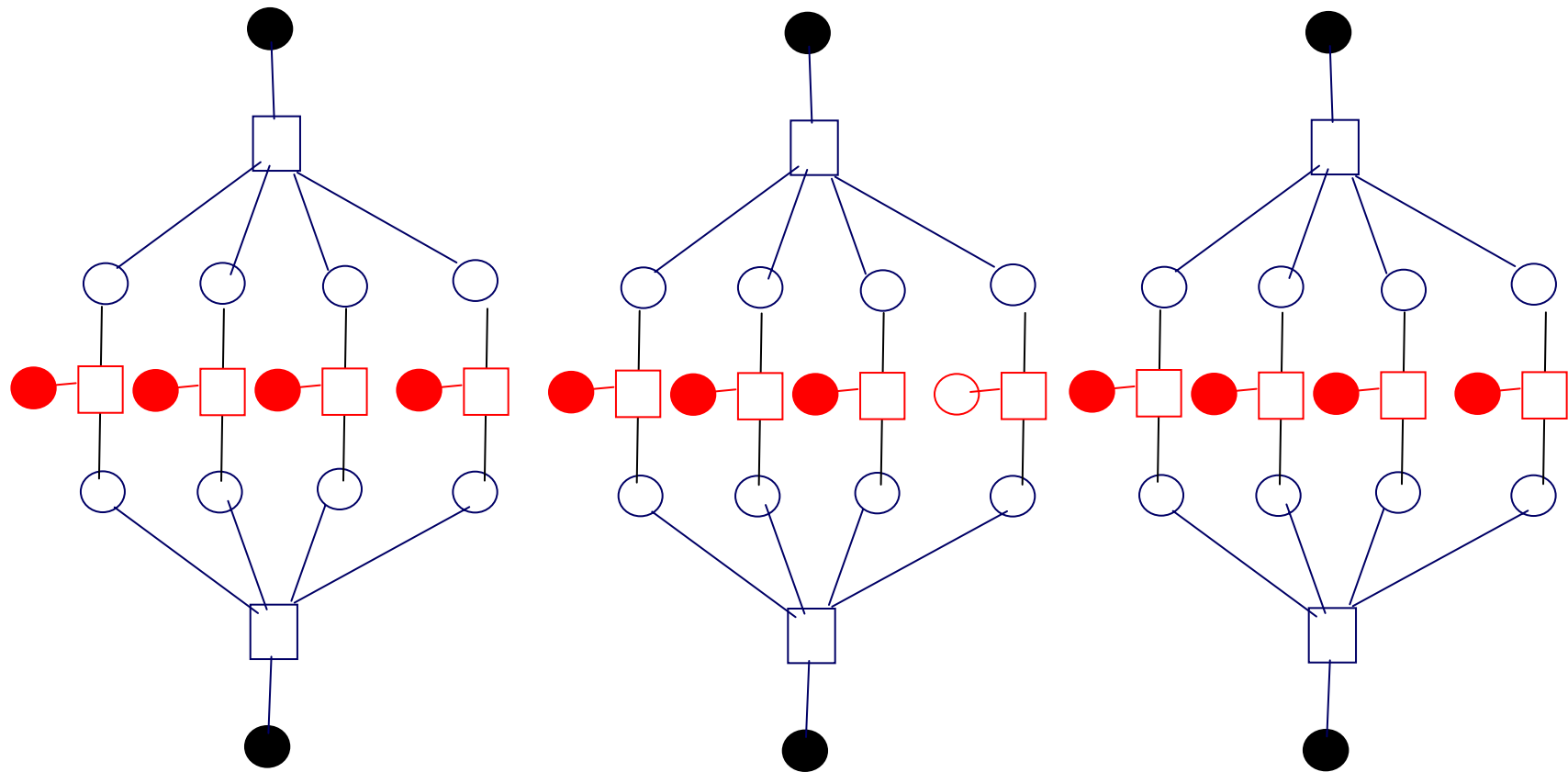

User 2 information bits

A Factor Graph for an IDMA System

User 1 information bits

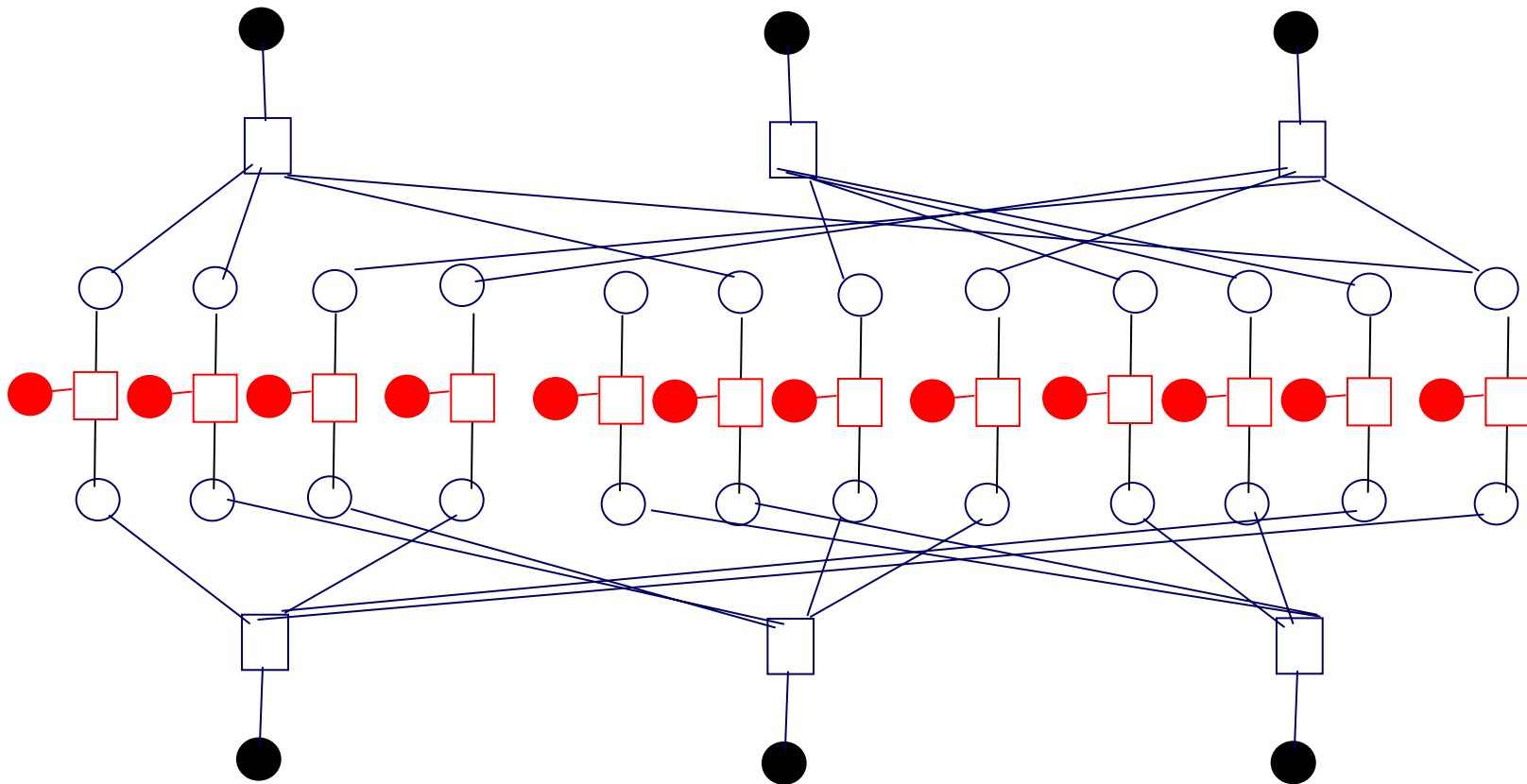

User 2 information bits

Outline

- Introduction
- **Iterative detection**
- Performance evaluation
- Multi-user gain in fading channels
- Other applications
- Conclusions

IDMA System Model

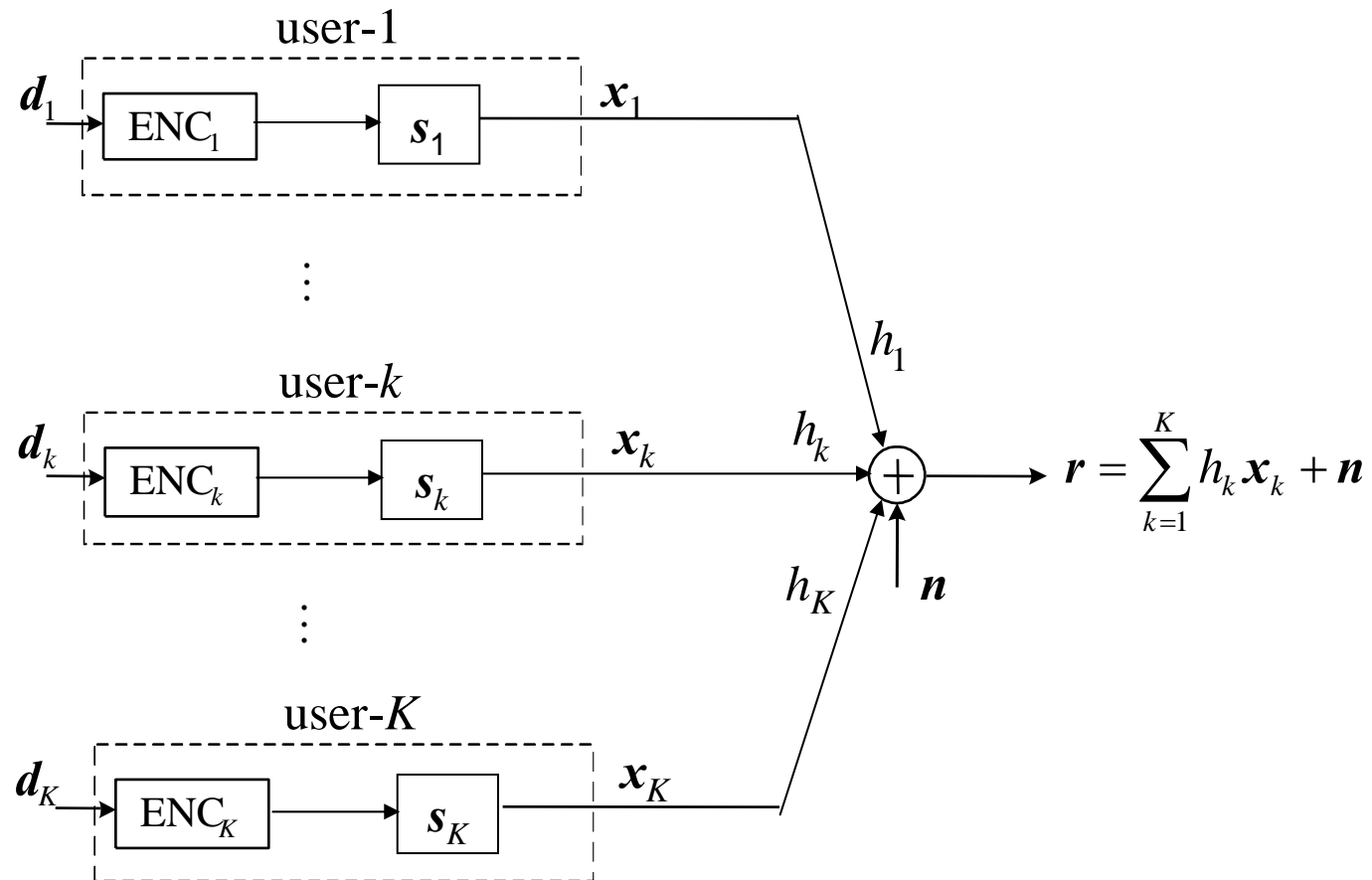

Message Passing at Channel Nodes

User 1 information bits

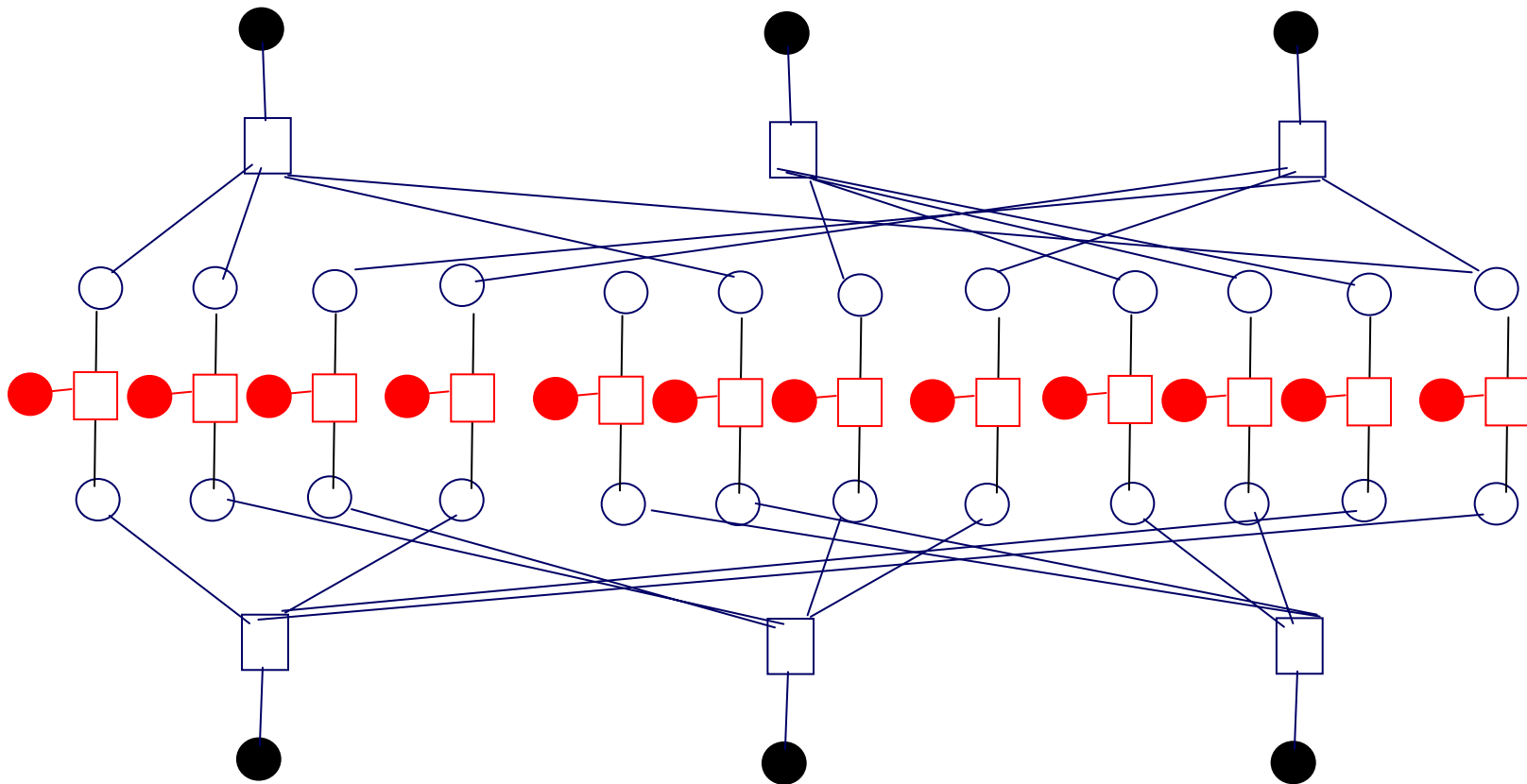

User 2 information bits

Gaussian Approximation Detection

Path model and Gaussian approximation

$$\begin{aligned} r(j) &= \sum_{k=1}^K h_k x_k(j) + n(j) \\ &= h_k x_k(j) + \zeta_k(j) \end{aligned}$$

← Gaussian

Estimation:
$$e(x_k(j)) = \frac{2h_k}{\text{Var}(\zeta_k(j))} \cdot (r(j) - \text{E}(\zeta_k(j)))$$

Some details:

$$\log \frac{\Pr(x_k(j) = +1)}{\Pr(x_k(j) = -1)} = \log \frac{\exp\left(-\frac{(r(j) - \text{E}(\zeta_k(j)) - h_k)^2}{2\text{Var}(\zeta_k(j))}\right)}{\exp\left(-\frac{(r(j) - \text{E}(\zeta_k(j)) + h_k)^2}{2\text{Var}(\zeta_k(j))}\right)} = \frac{2h_k}{\text{Var}(\zeta_k(j))} \cdot (r(j) - \text{E}(\zeta_k(j)))$$

Chip-by-Chip (CBC) Detection Algorithm

$$\text{Step 1. } E(r(j)) = \sum_{k=1}^K h_k E(x_k(j)) \quad \text{Var}(r(j)) = \sum_{k=1}^K |h_k|^2 \text{Var}(x_k(j))$$

$$\text{Step 2. } E(\zeta_k(j)) = E(r(j)) - h_k E(x_k(j)) \quad \text{Var}(\zeta_k(j)) = \text{Var}(r(j)) - |h_k|^2 \text{Var}(x_k(j))$$

$$\text{Step 3. } e(x_k(j)) = \frac{2h_k}{\text{Var}(\zeta_k(j))} \cdot (r(j) - E(\zeta_k(j)))$$

Notes:

- (1) There is no matrix operation.
- (2) $E(x_k(j))$ and $\text{Var}(x_k(j))$ are the feedback from the decoders.

A Factor Graph for an IDMA System

User 1 information bits

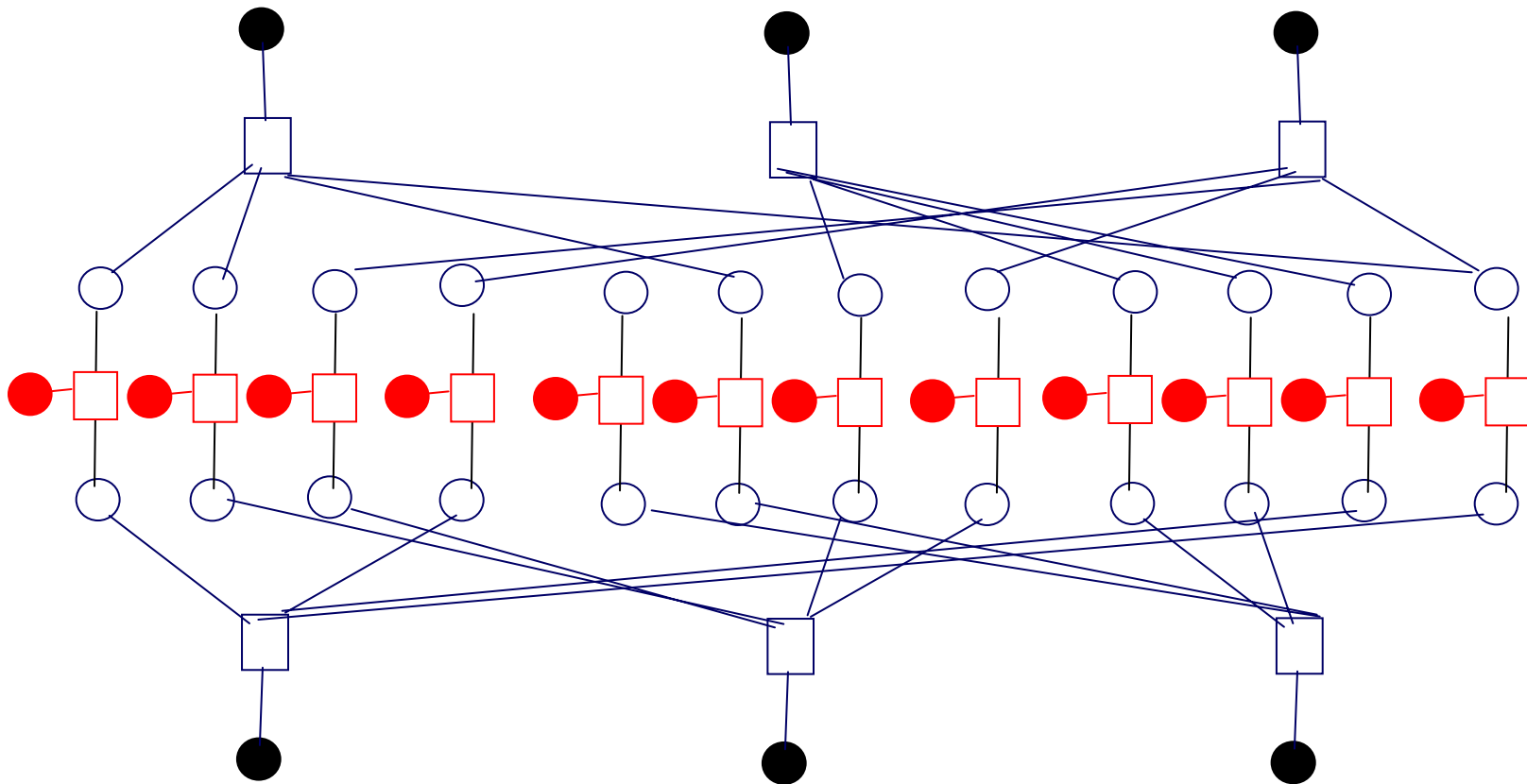

User 2 information bits

Chip-by-Chip Multiuser Detection

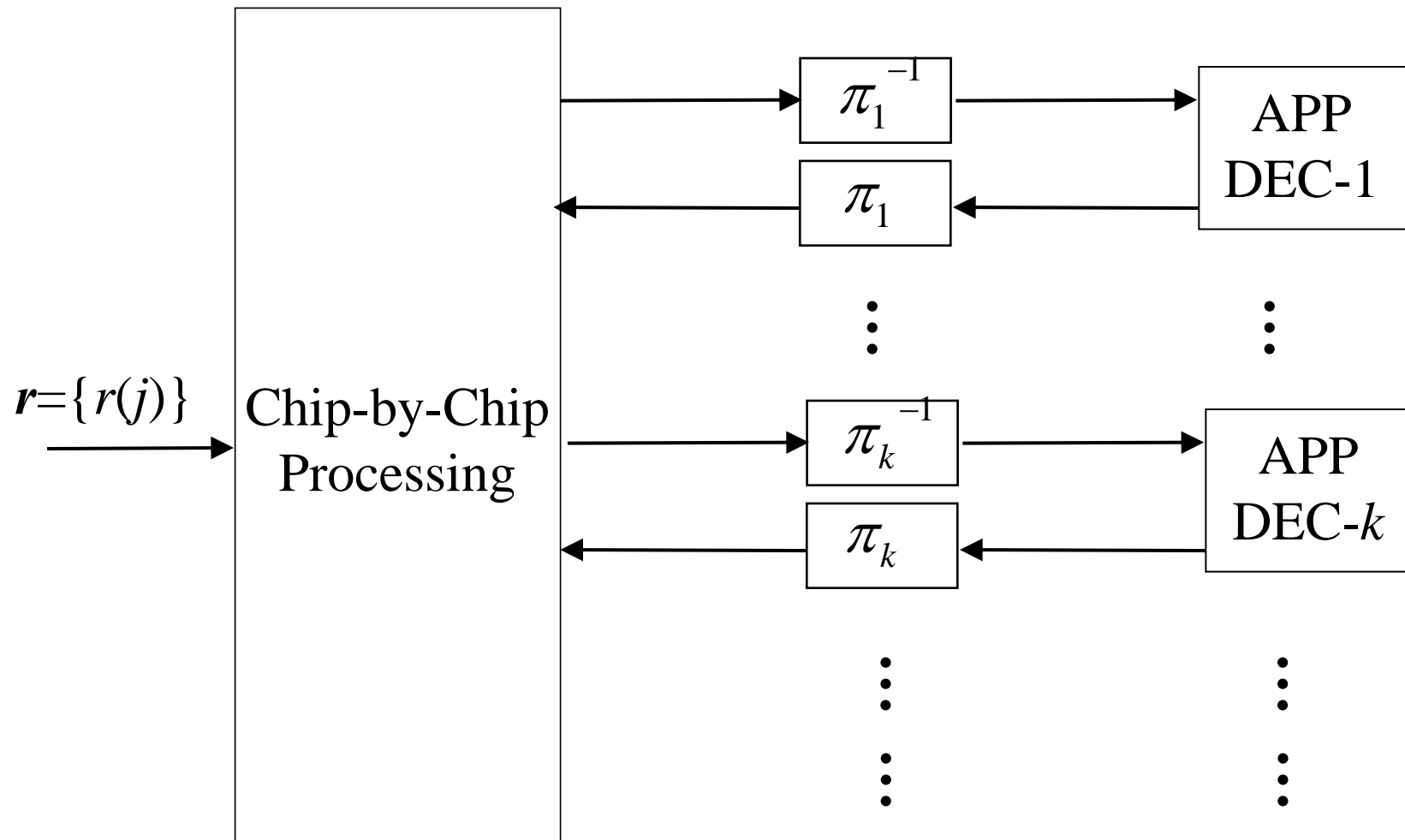

Complexity

6 additions and 6 multiplications **per chip** per iteration **per user**.

Complexity (per user) is independent of user number K .

Comparison: To achieve good performance, the cost for MMSE CDMA multi-user detection is $O(K^2)$ due to matrix operations.

Un-coded IDMA

Rate-1/8 repetition coding

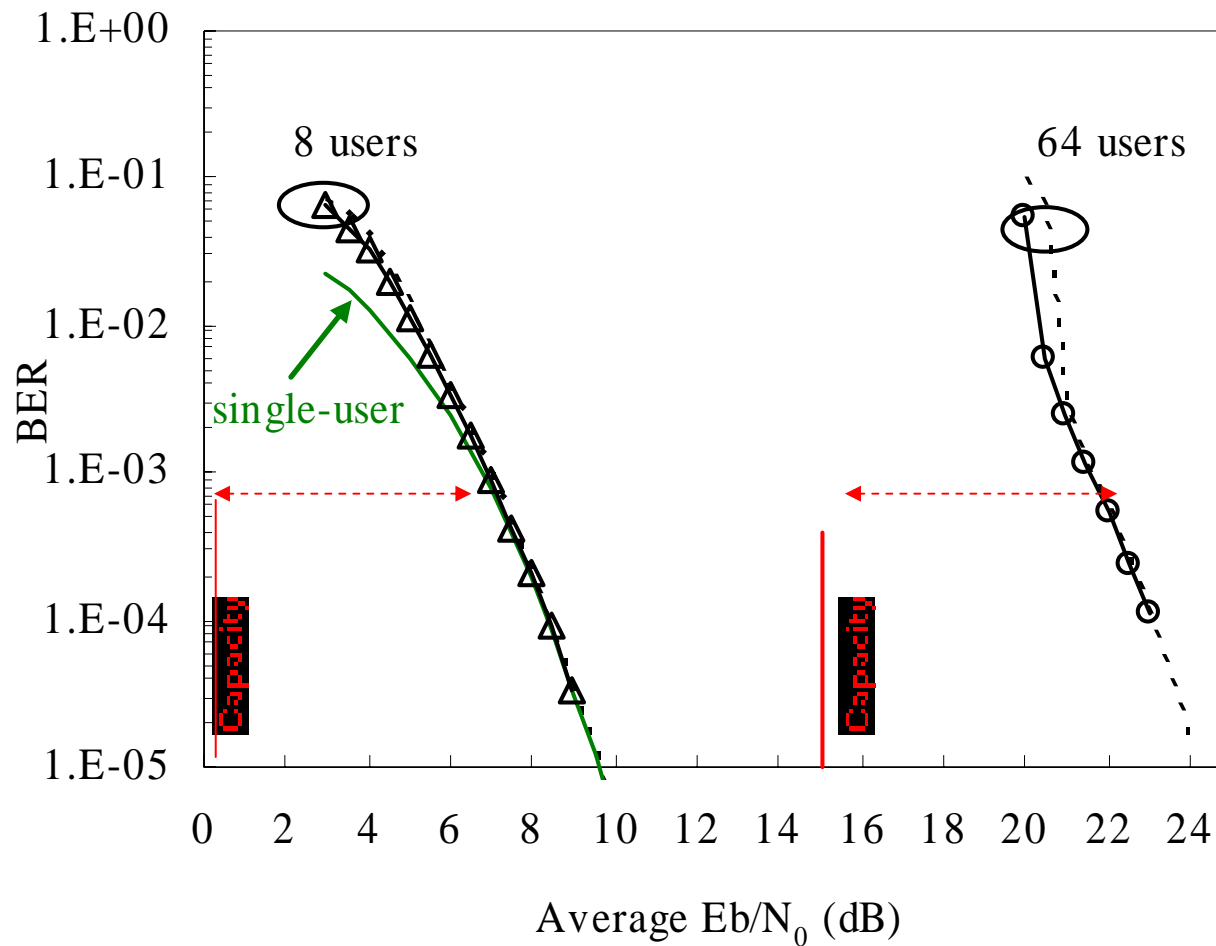

Convolutional-Repeat Coded IDMA

Rate $\frac{1}{2}$ and rate $\frac{1}{4}$ repetition coding. Overall rate = $\frac{1}{8}$.

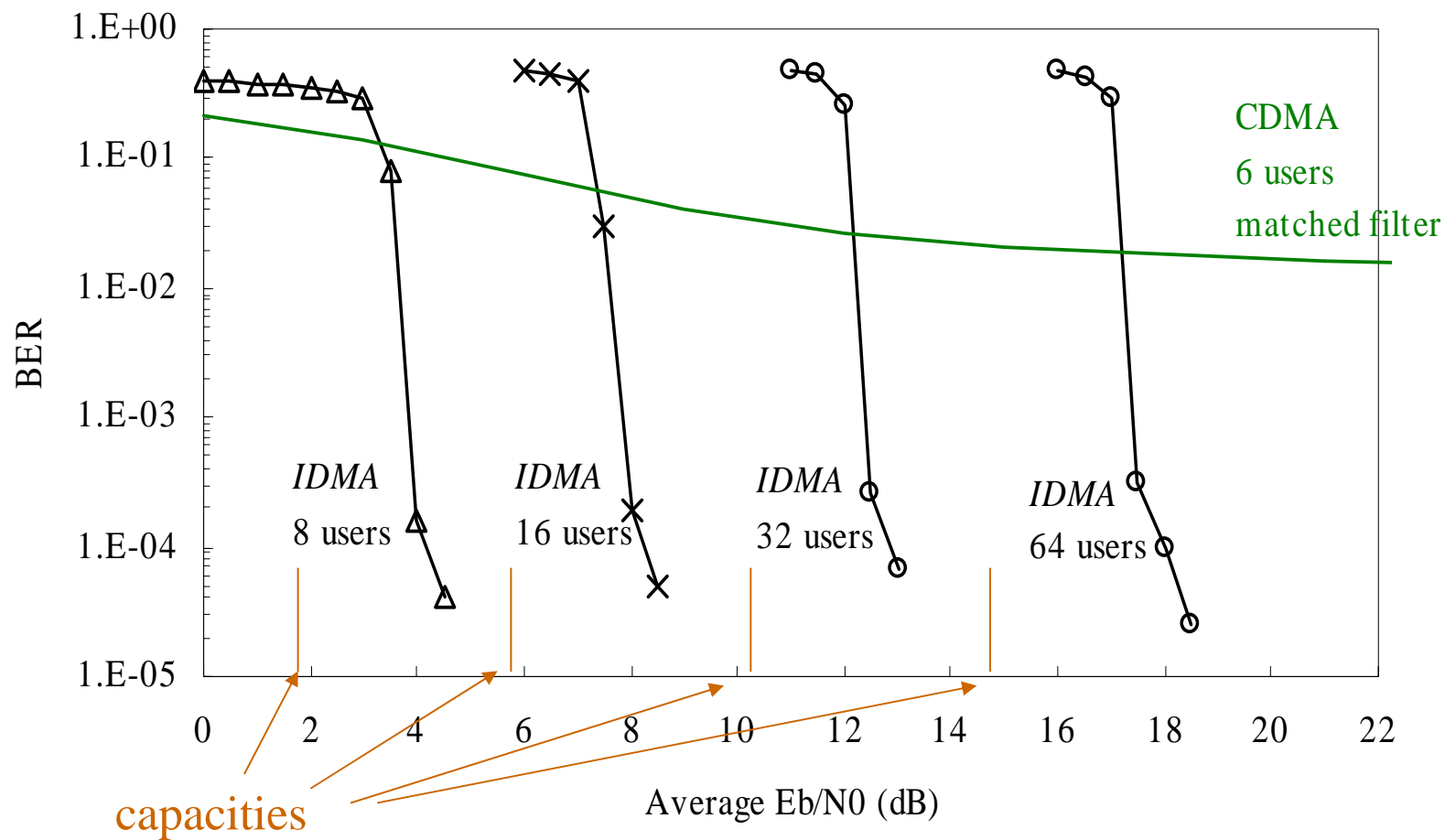

Outline

- Introduction
- Iterative detection
- **Performance evaluation**
- Multi-user gain in fading channels
- Other applications
- Conclusions

SNR Evolution for an IDMA Detector

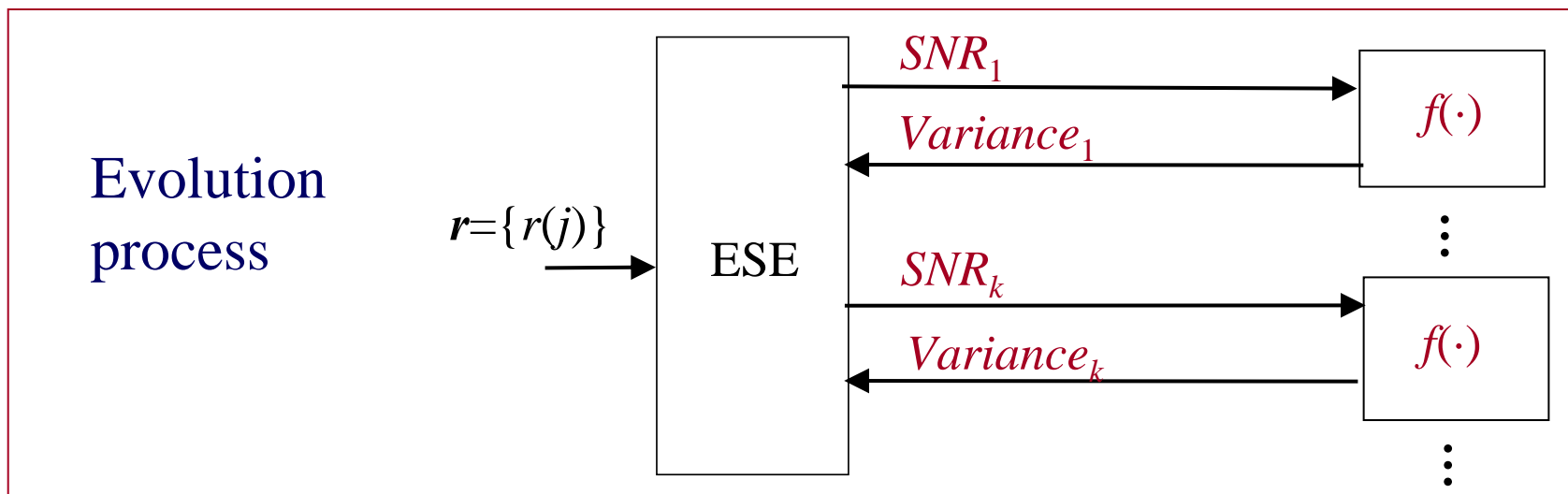
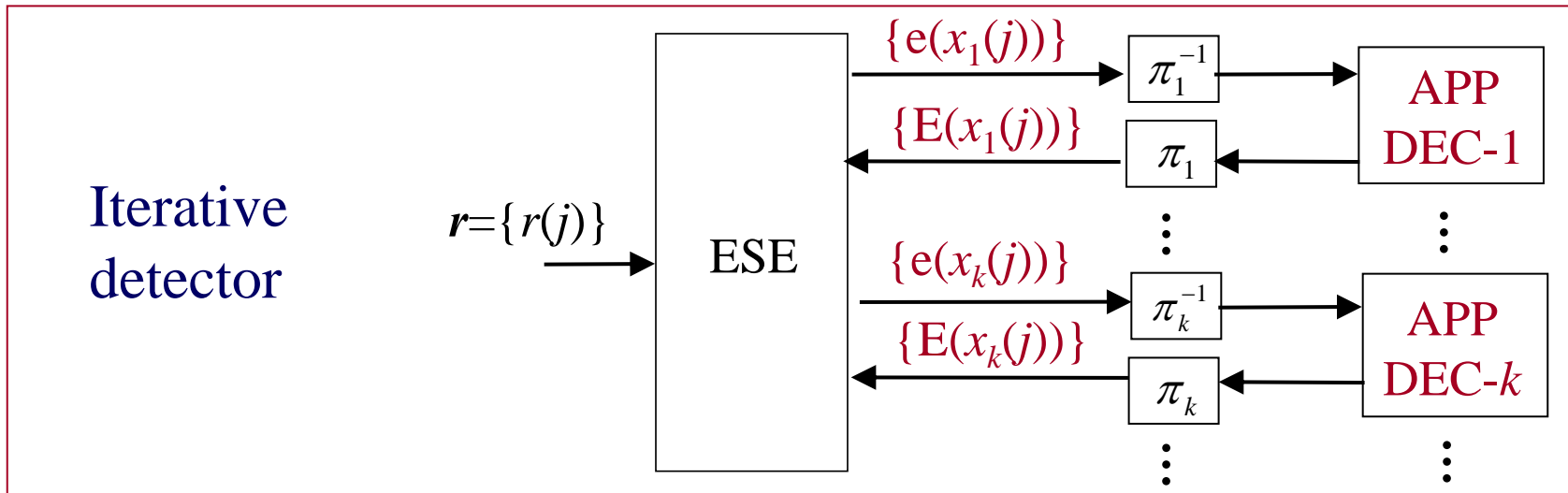

IDMA Performance Evaluation

Received signal:

$$r(j) = \sum_{k=1}^K \sqrt{p_k} h_k x_k(j) + n(j)$$

Gaussian

$$= \sqrt{p_k} h_k x_k(j) + \sum_{i \neq k} \sqrt{p_i} h_i x_i(j) + n(j)$$

SNR evolution:

$$SNR_k^{(new)} = \frac{p_k |h_k|^2}{\sum_{i \neq k} p_i |h_i|^2 f_i(SNR_i^{(old)}) + \sigma^2}$$

Initialization:

$$SNR_k^{(0)} = 0, \forall k$$

SNR Evolution for an IDMA Decoder

The iterative detector can be characterized by the following SNR evolution process:

Evolution
formula

$$SNR_k^{(new)} = \frac{|h_k|^2 p_k}{\sum_{i \neq k} |h_i|^2 p_i f_i(SNR_i^{(old)}) + \sigma^2}$$

Evolution
process

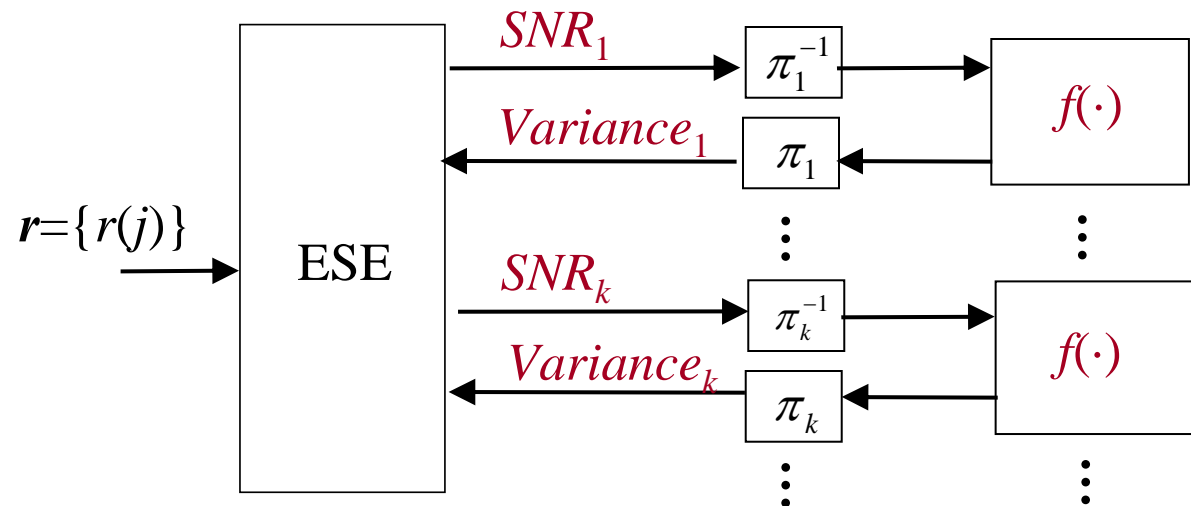

This is much simpler and faster than simulation.

Un-coded IDMA

Rate-1/8 repetition coding

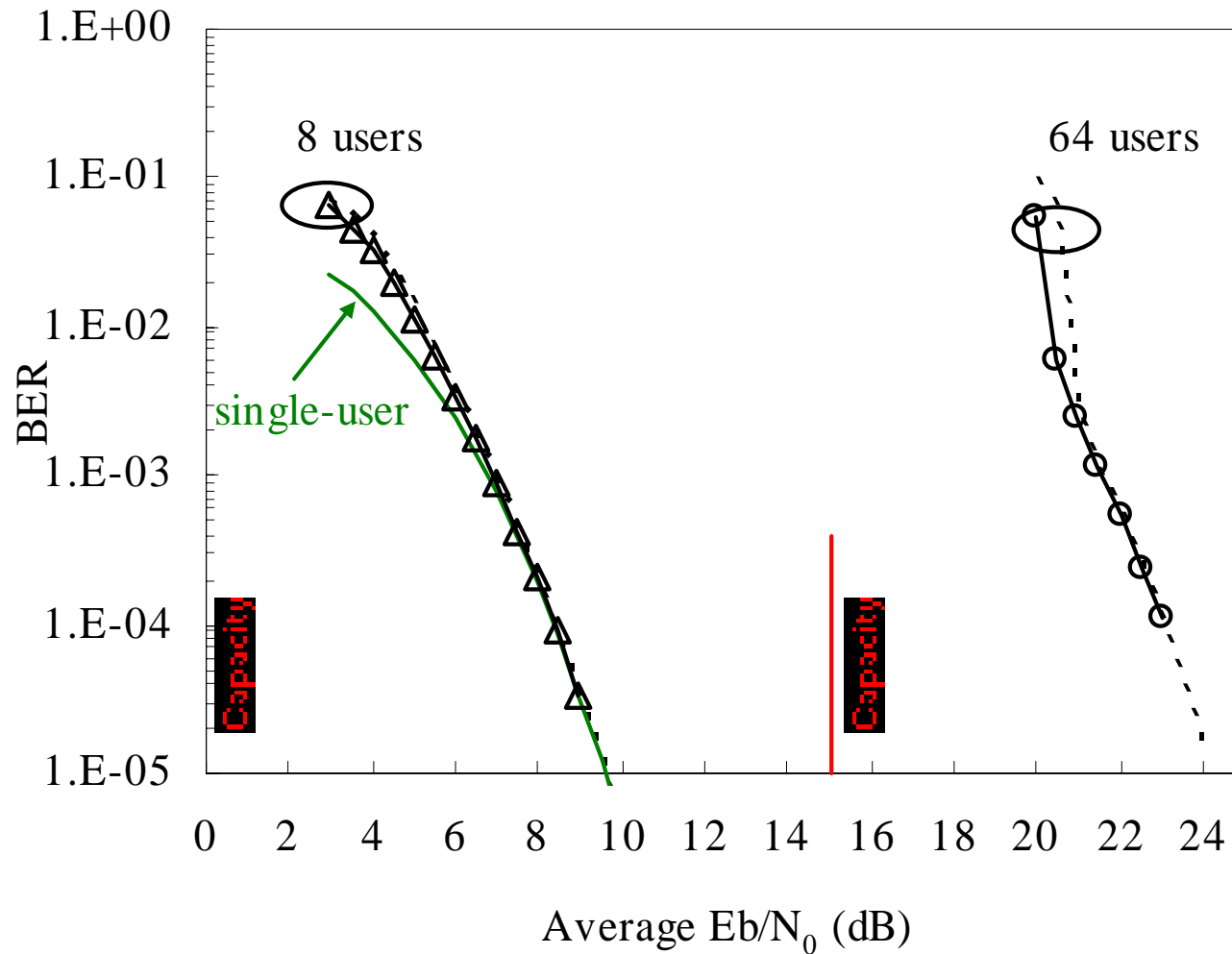

Outline

- Introduction
- Iterative detection
- Performance evaluation
- **Multi-user gain in fading channels**
- Other applications
- Conclusions

Multi-User Gain in Fading Channels

Sum-rate = 8 bits/chip, $P_{out} = 0.01$

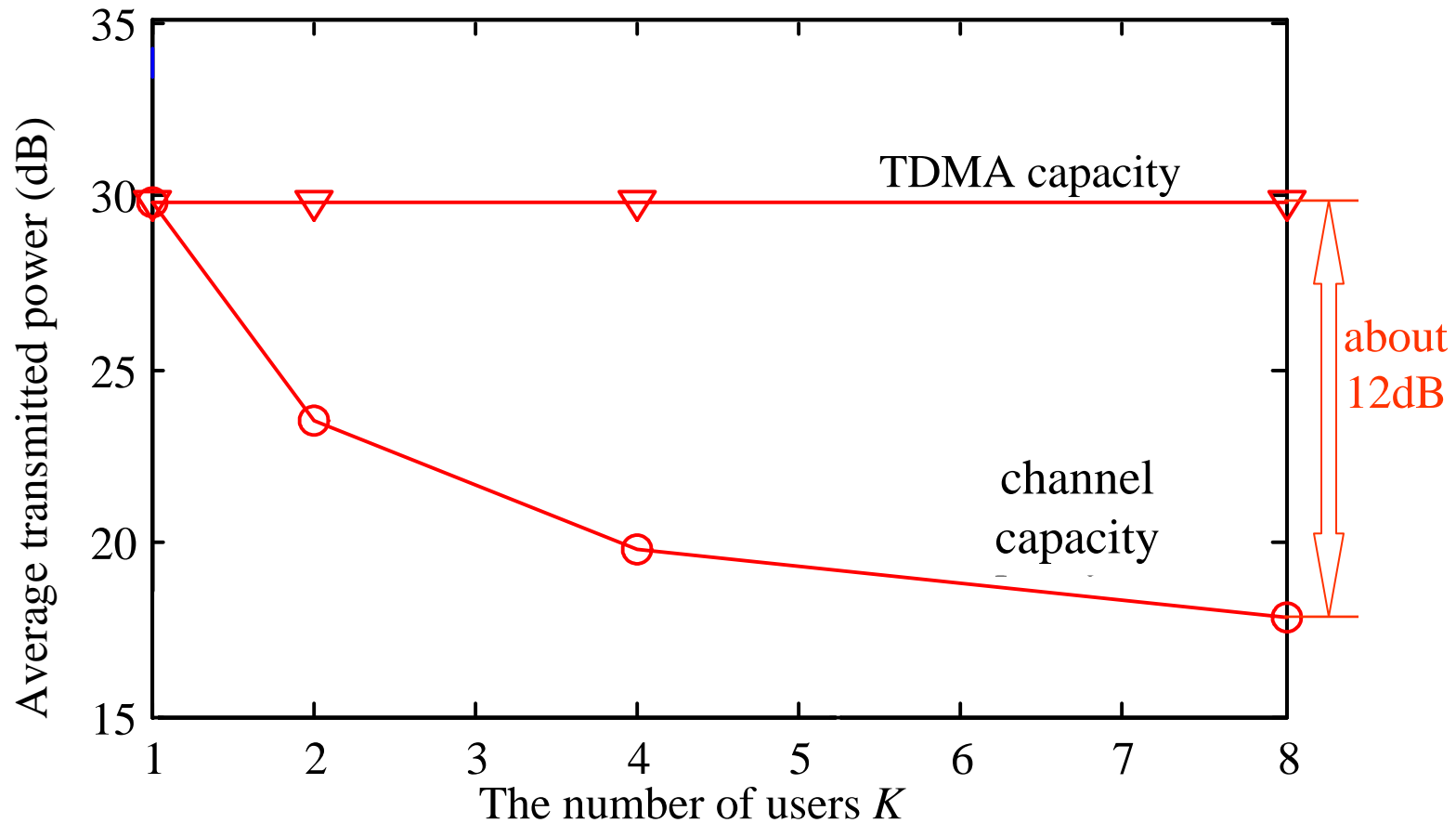

Multi-User Gain in Fading Channels

Sum-rate = 8 bits/chip, $P_{out} = 0.01$

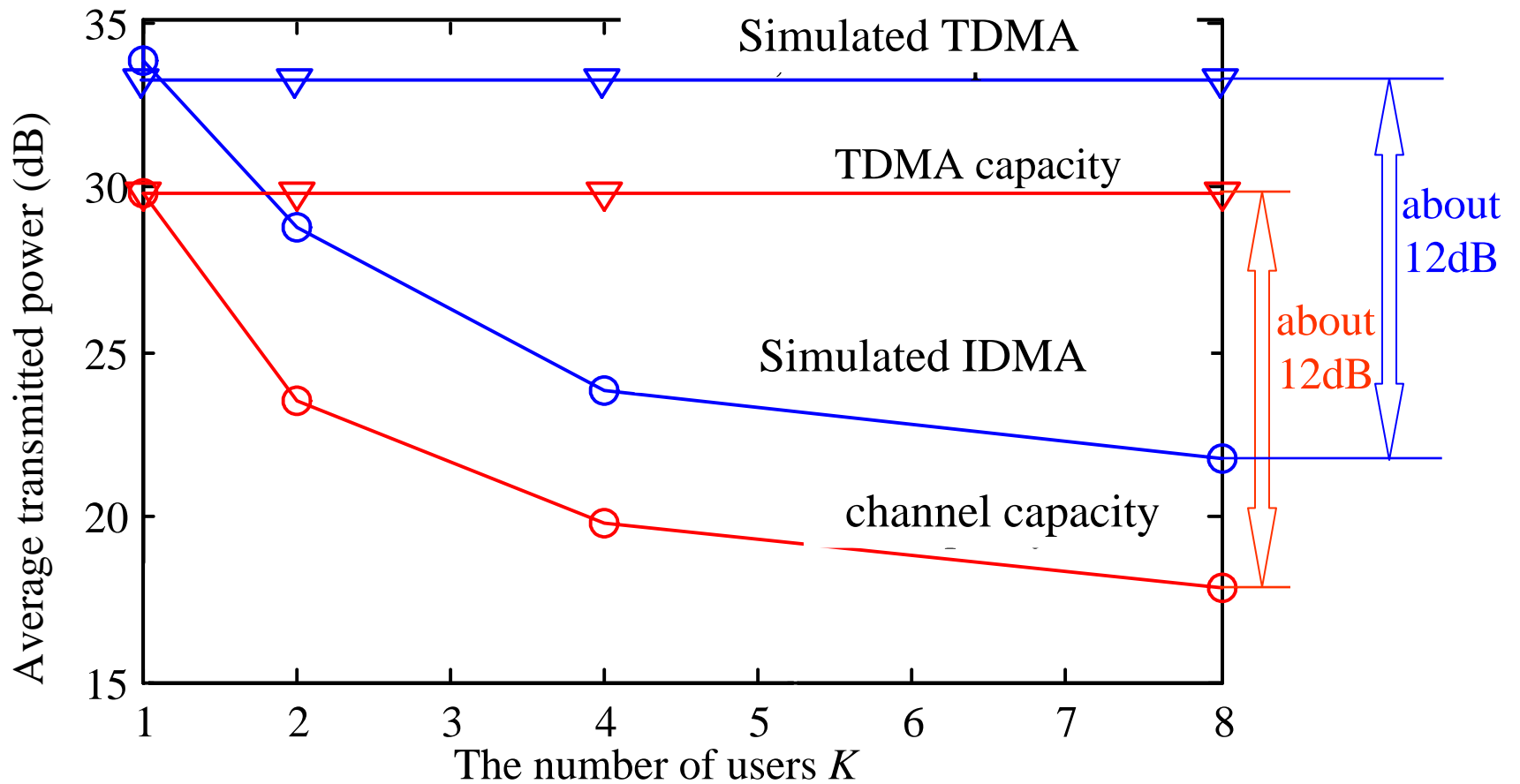

IDMA-OFDM



Basic Principle:

- Randomly distribute information on the sub-carriers on frequency- time.
- Multi-layer structure using superposition coding.
- Iterative detection.

This is proposed by Zhou et al and by Mahafeno et al. It has been considered as an option in 3GPP LTE.

OFDM-IDMA vs BICM-OFDM

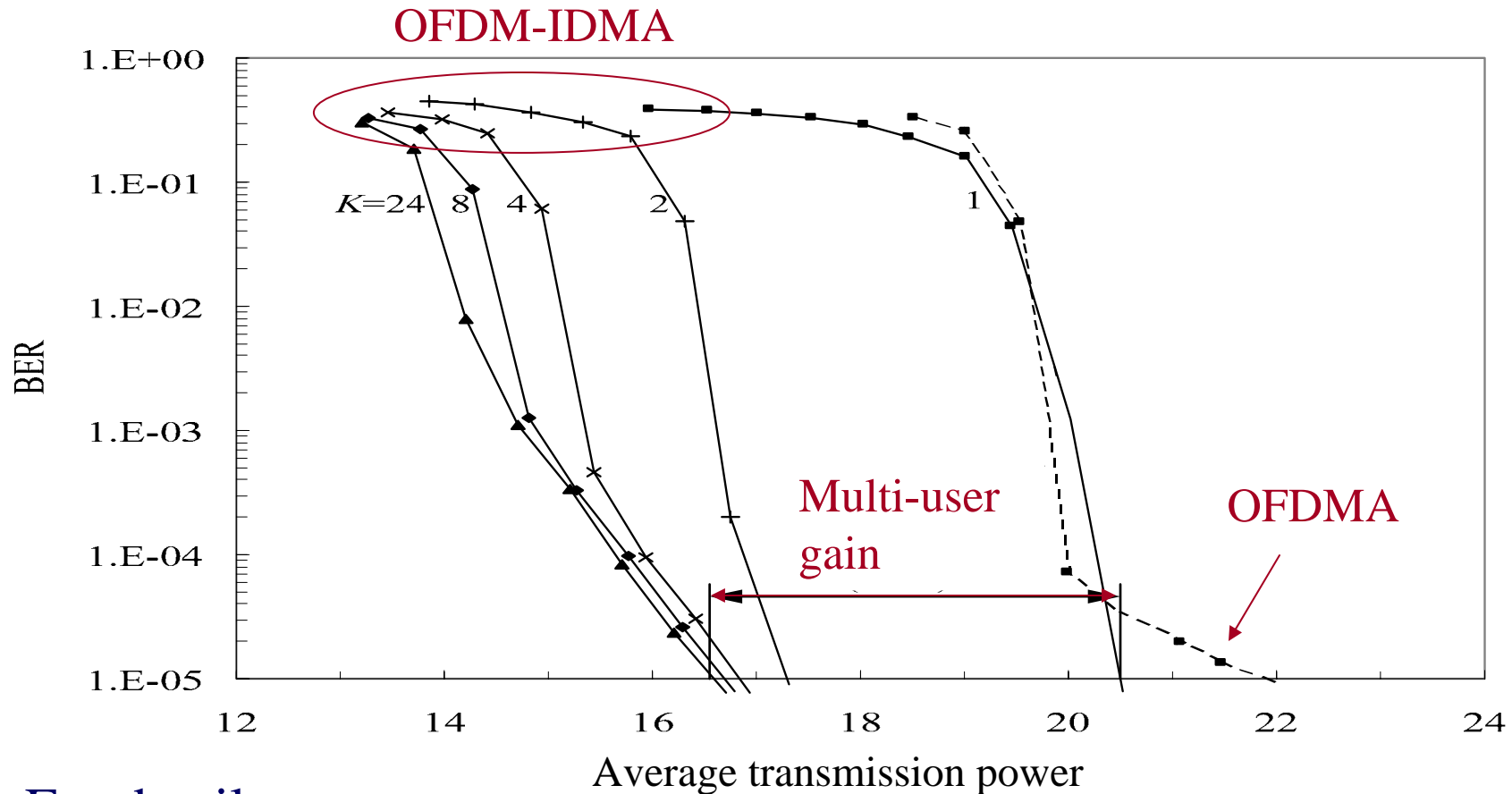

For details, see

Li Ping, Qinghua Guo, and Jun Tong, "The OFDM-IDMA approach to wireless communication systems," *IEEE Wireless Commun. Mag.*, June 2007.

Outline

- Introduction
- Iterative detection
- Performance evaluation
- Multi-user gain in fading channels
- **Other applications**
- Conclusions

IDMA

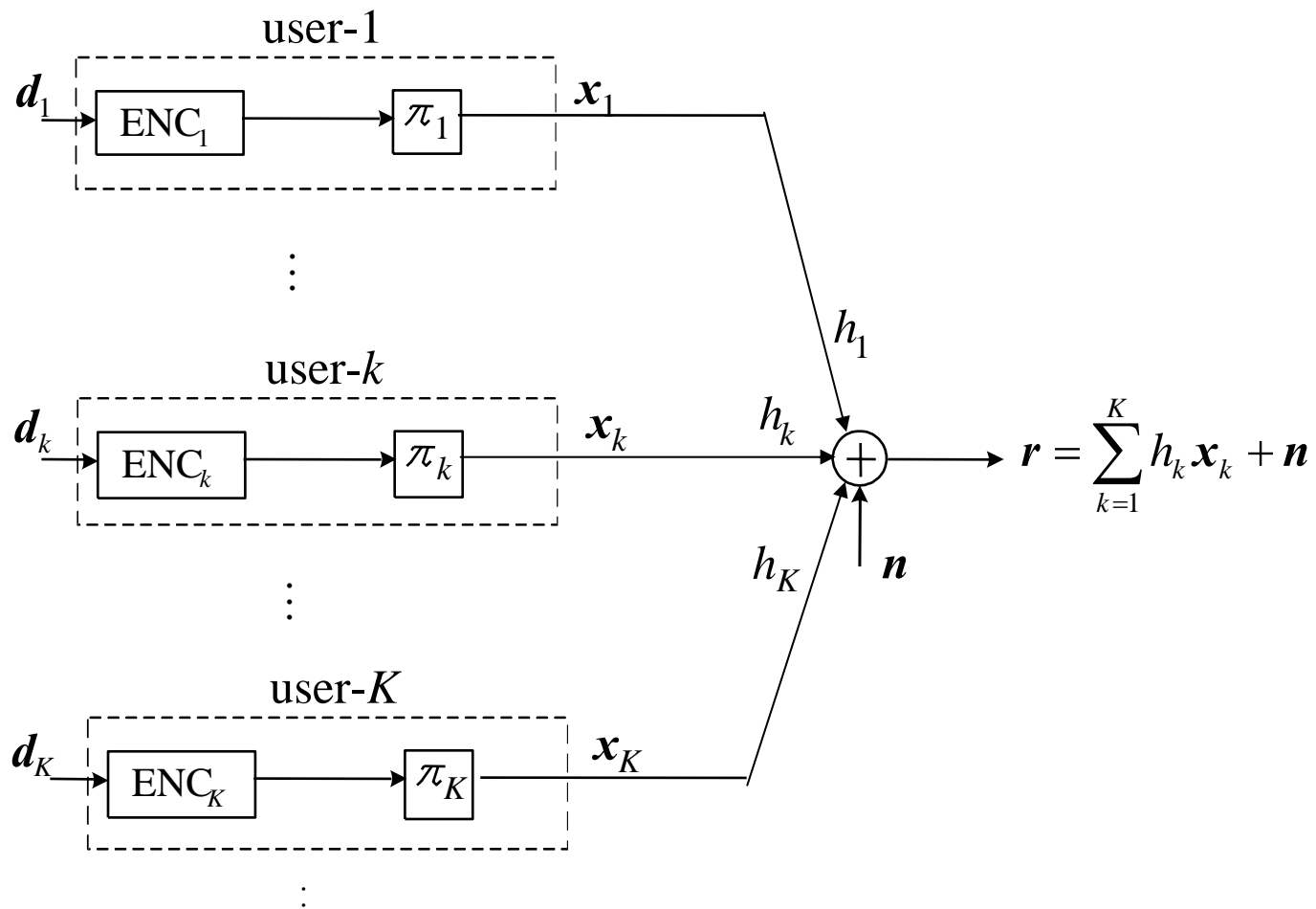

Superposition Coded Modulation (SCM)

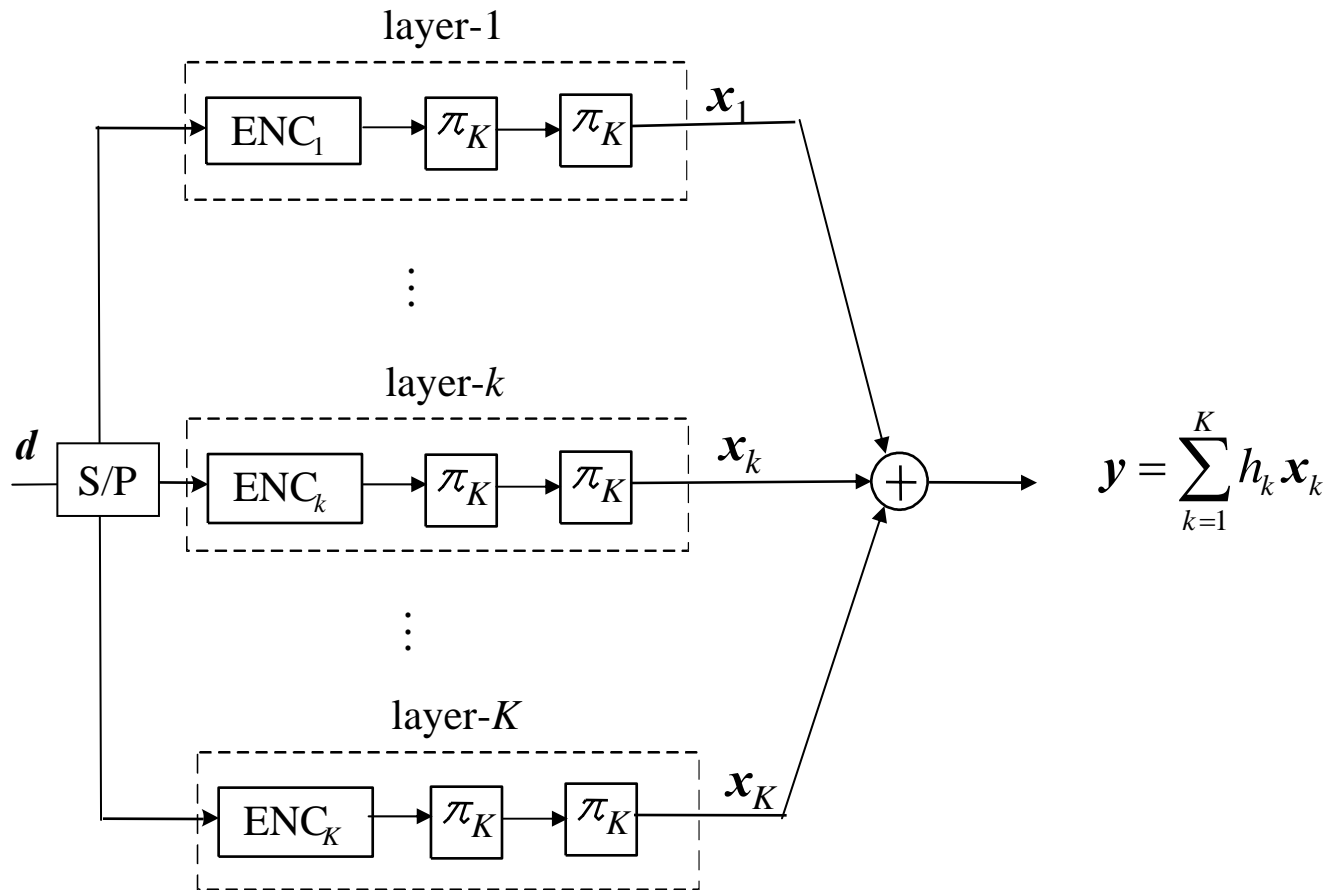

Jun Tong and Li Ping, "Superposition coding with peak power limitation" to appear in *IEEE Trans Inform. Theory*. Available at <http://www.ee.cityu.edu.hk/~liping/Research/Journal/index.html>

Comparison of SCM and BICM (1)

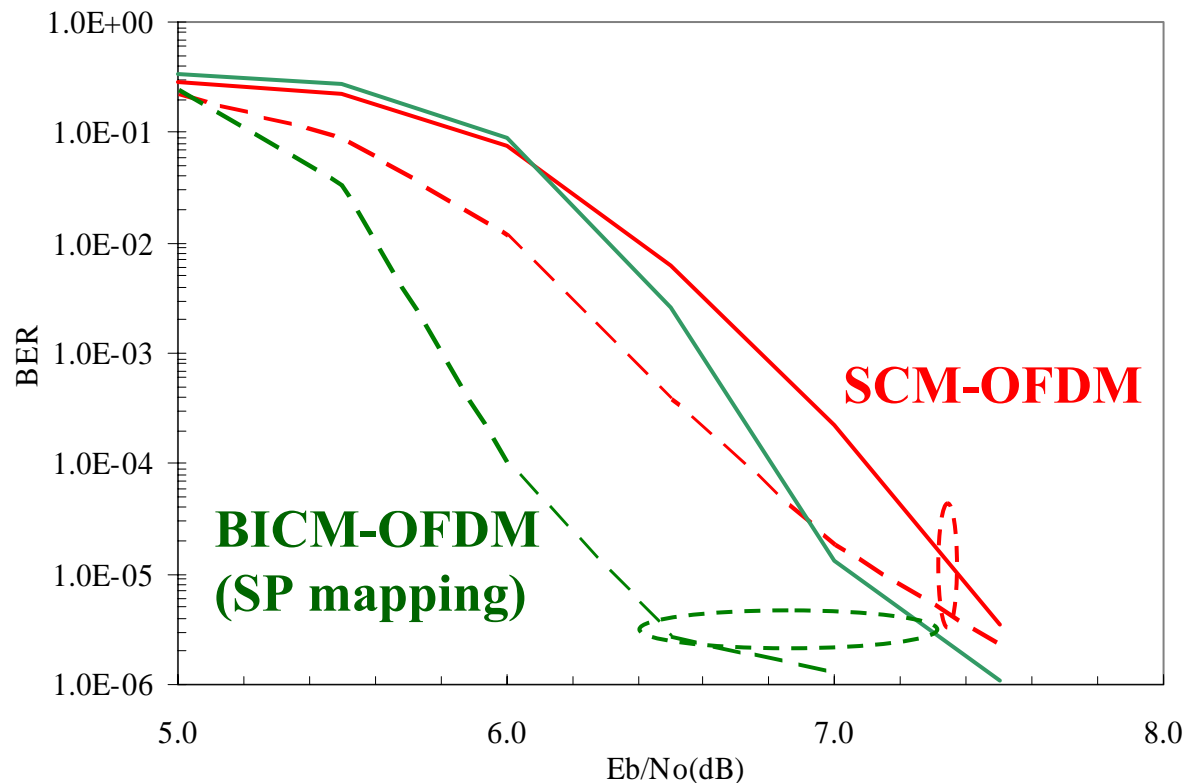

SCM-OFDM vs BICM-OFDM over fading channels, with and without clipping; $R = 2$ b/s, clipping ratio = 3 dB

Comparison of SCM and BICM (2)

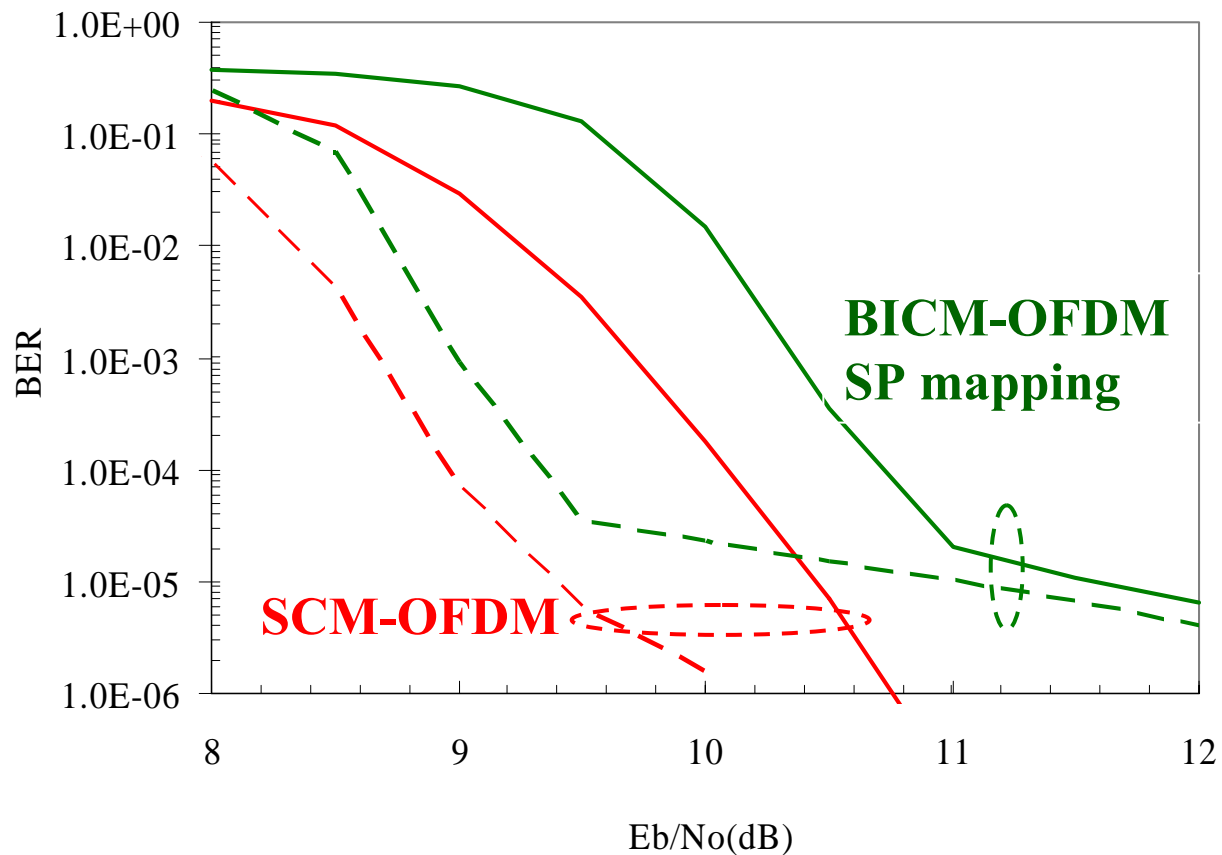

SCM-OFDM vs BICM-OFDM over fading channels, with and without clipping; $R = 3$ b/s, clipping ratio = 3 dB

Comparison of SCM and BICM (3)

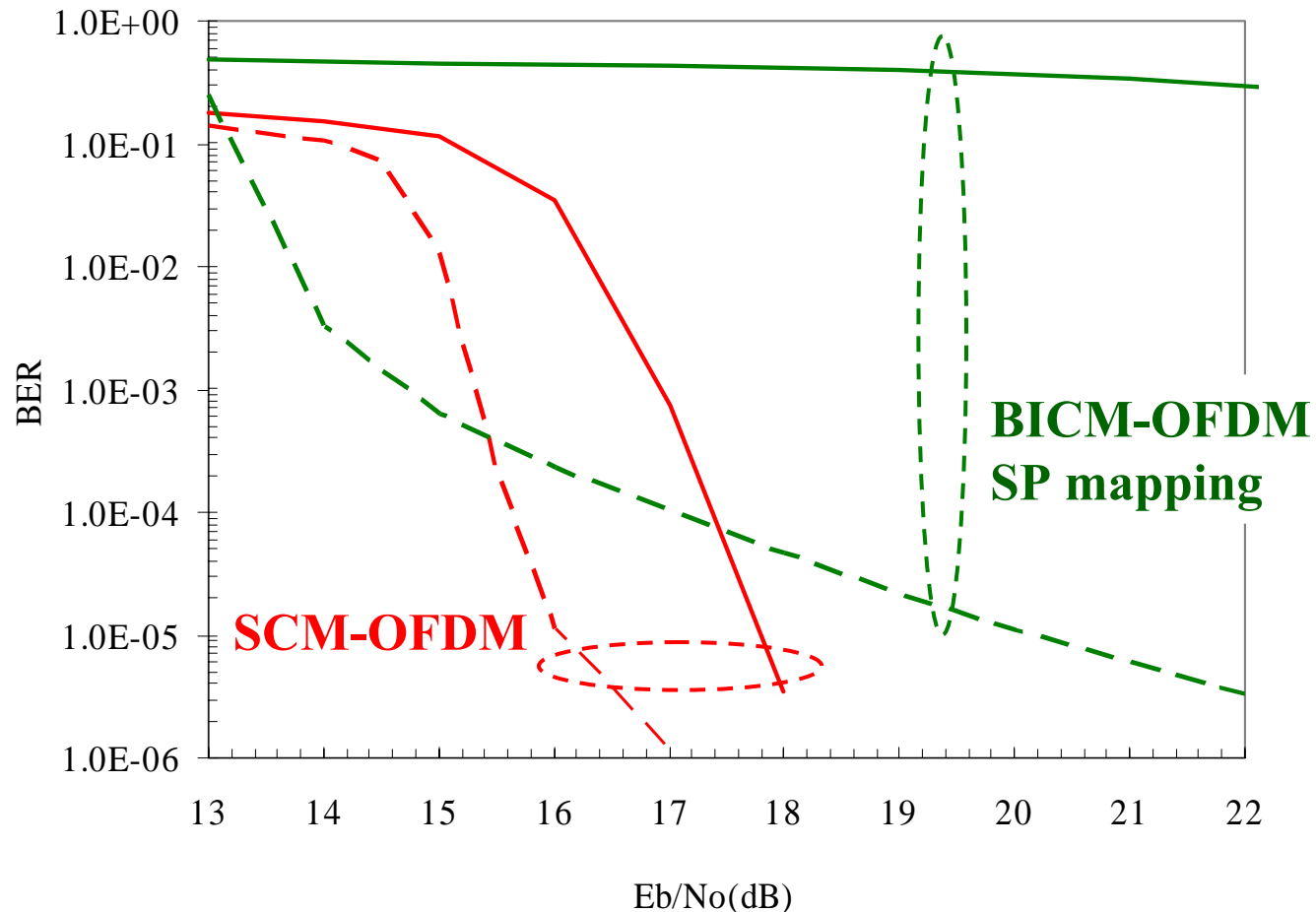

SCM-OFDM vs BICM-OFDM over fading channels, with and without clipping; $R = 5$ b/s, clipping ratio = 3 dB

IDM Space-Time Coding

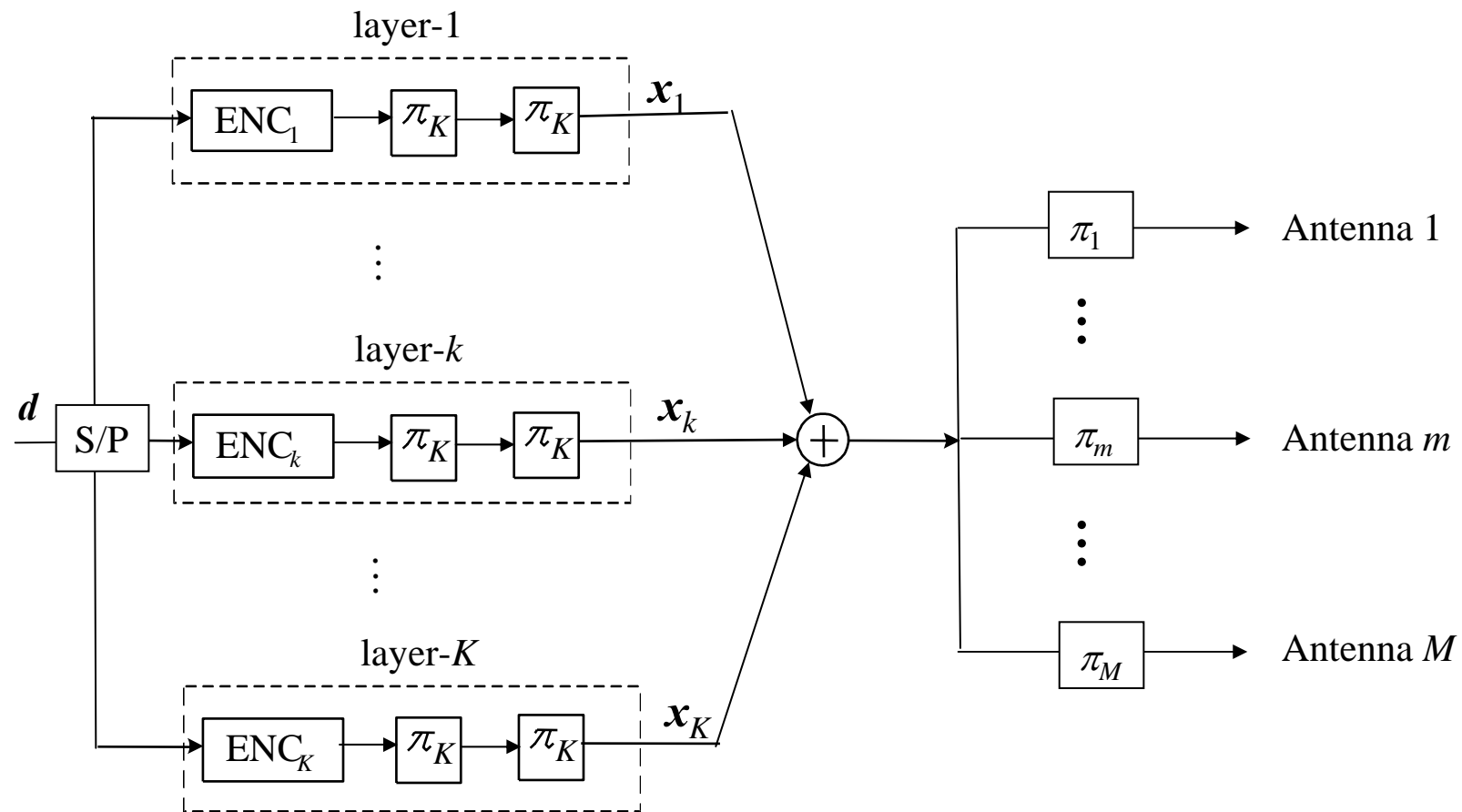

Keying Wu and Li Ping, "A Quasi Random Approach to Space-Time Coding" *IEEE Trans Inform. Theory*, pp. 1073 – 1085, March 2008.

IDM Space-Time Coding Performance

Overall rate = 4 bits/symbol

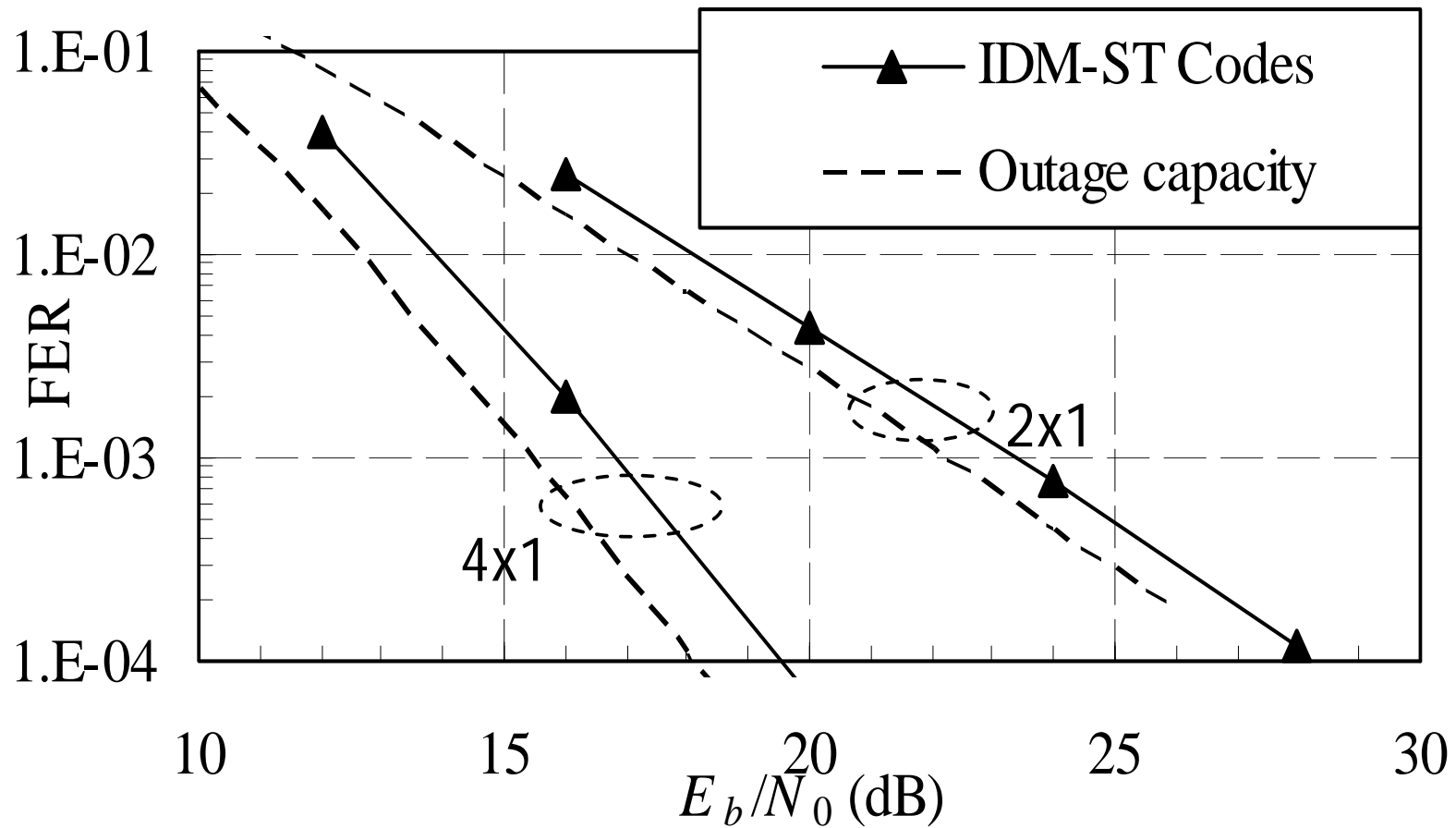

Multi-Path Channels

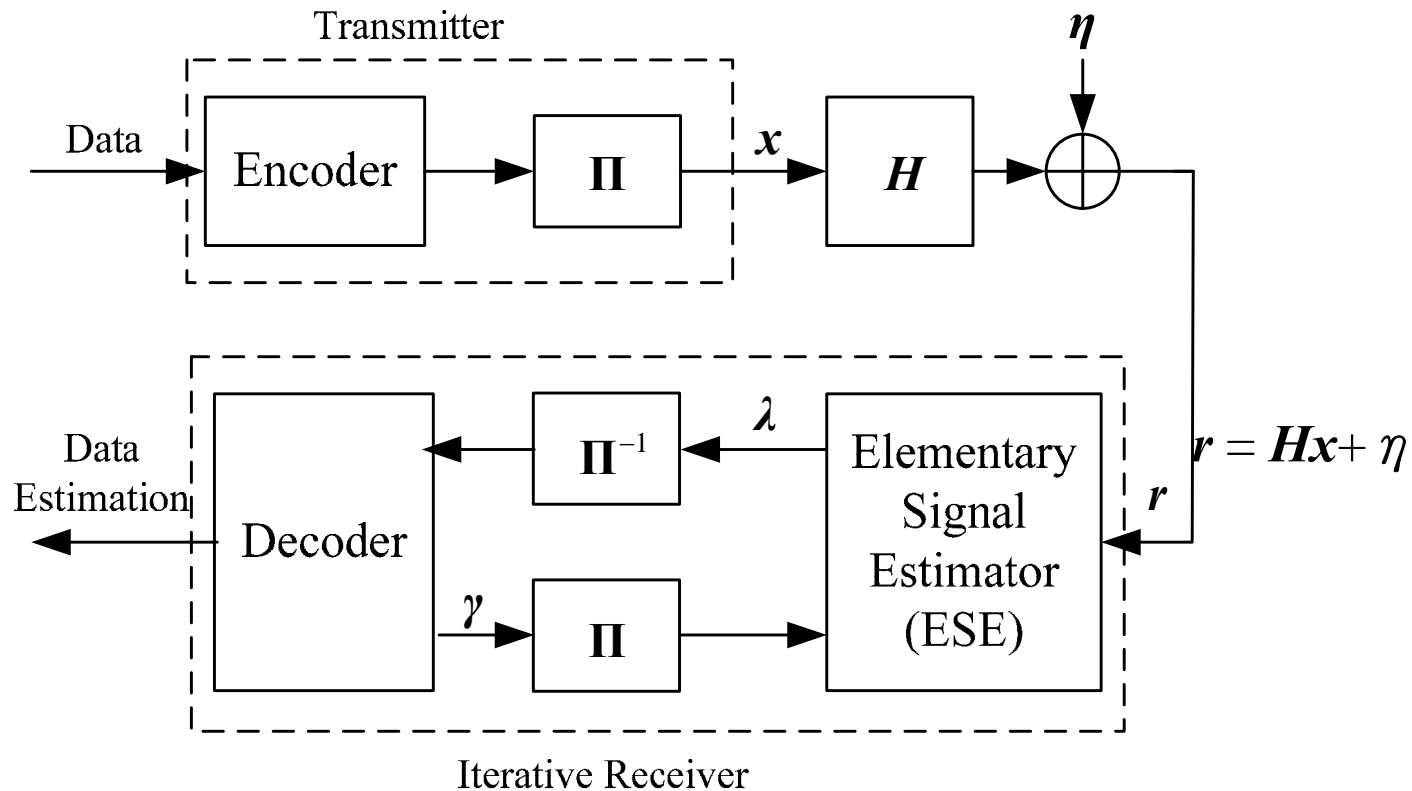

See

Xiaojun Yuan, Qinghua Guo, Xiaodong Wang and Li Ping, "Evolution analysis of low-cost iterative equalization in coded linear systems with cyclic prefixes," *IEEE J. Select. Areas Commun.* Feb. 2008.

Application in Ad Hoc Networks

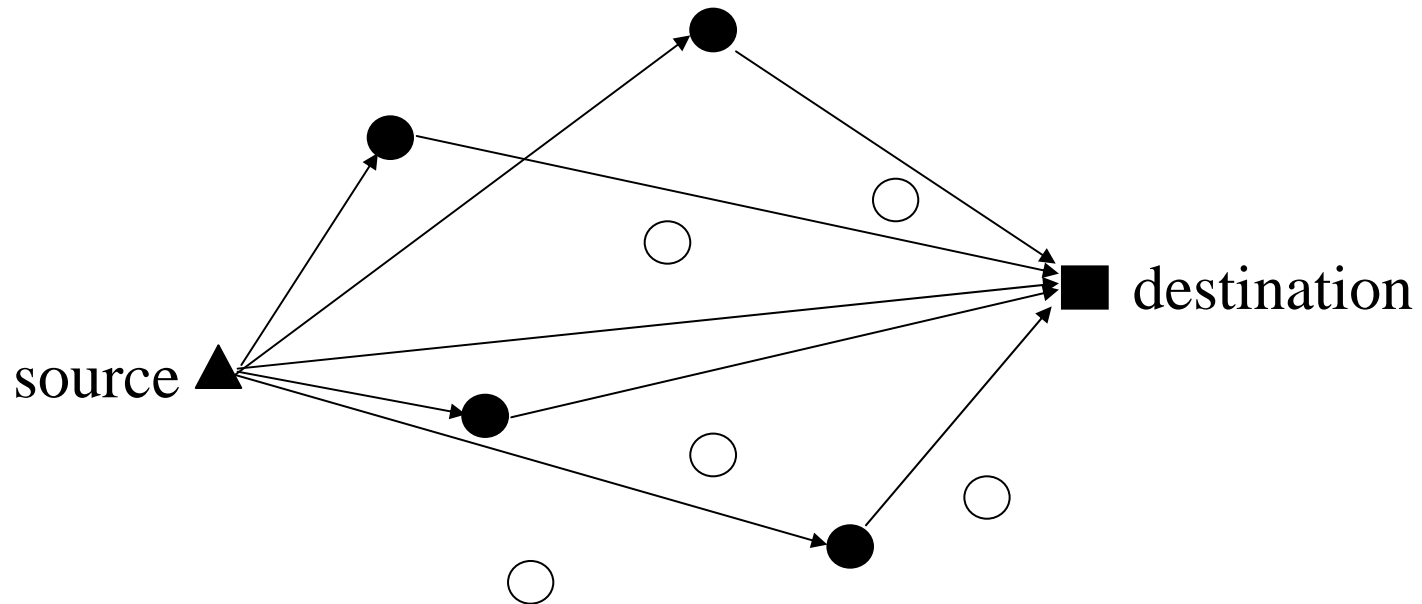

Conclusions: Features of IDMA

- low receiver cost
- de-centralized (i.e., asynchronous) control,
- simple treatment of ISI,
- cross-cell interference mitigation,
- diversity against fading,
- power efficiency
- easy for adaptive rate control
- high user number and high spectral efficiency
- suitable for wide or narrow band transmission