

# Maximising Renewable Energy Integration within Electrical Networks

Dr Gareth P Harrison and Dr A Robin Wallace

School of Engineering & Electronics,  
University of Edinburgh, Edinburgh EH9 3JL, UK.

Tel: +44 131 650 5583  
Fax: +44 131 650 6554  
Email: Gareth.Harrison@ed.ac.uk

## Abstract

The worldwide capacity of renewable energy generation is set to increase significantly. With the resource dictating that much of this new plant connect to distribution networks a range of technical and economic issues arise. This paper briefly reviews the technical problems associated with the connection of renewable energy at distribution-level and the means of integrating renewables available at present and in the near future. Further, it examines the issues surrounding current connection practices in terms of the potential for inadvertently limiting network capability to absorb new renewable energy. Finally, it demonstrates the use of optimal power flow techniques that could assist in maximising renewable generation capacity in the electricity market.

## 1 Introduction

To enable the UK to meet its obligations under the Kyoto Protocol and, to go further to reduce carbon dioxide emissions by 20% by 2010, the Government has set targets for renewable energy generation. Under the Renewables Obligation [1] electricity suppliers must ensure that 10% of the energy they provide to consumers in England and Wales (18% in Scotland) is derived from renewable resources. While the 2010 target is quite modest, the targets for later years are expected to be more significant: the Scottish Executive is proposing a target of 40% by 2020 [2]. Such targets will require the exploitation of a significant amount of Scotland's remaining renewable potential which is estimated at around 59 GW [3].

The location of renewable resources and the likely plant capacities imply that schemes will generally be connected to distribution networks. Distribution networks were not designed to accept the power injections from these distributed generation (DG) sources and their connection creates a wide range of technical problems. While a range of options exist to mitigate adverse impacts, under current commercial arrangements the developer will largely bear the financial responsibility for their implementation. The economic implications can make potential schemes less attractive and, in some instances, have been an impediment to renewable development.

This paper provides a brief review of the technical problems associated with the connection of DG, the mitigation methods currently available and examines the shortcomings of current practice in connecting DG. Finally, a new technique is outlined that could facilitate the growth of DG capacity.

## 2 Network Impacts

Renewable resources are generally located in areas with low population and load densities. Historically, the distribution networks in these areas were designed to supply customer demand that tended to reduce with distance from the transmission system. The networks were operated passively to ensure that the quality of electricity supplied to customers was kept

within statutory limits. Connection of distributed generation fundamentally alters the operation of distribution networks. The changes and impacts are well-documented [4] and include bi-directional power flow, voltage rise, increased fault levels, altered transient stability and degradation of protection operation and co-ordination (Figure 1).

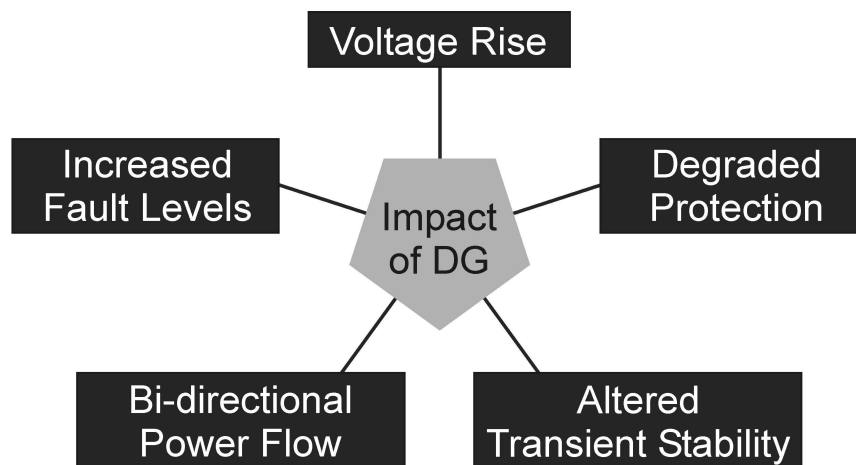

Figure 1: Key impacts on the distribution network

The impacts arising from an individual DG scheme undergo detailed examination when the developer applies to connect. Distribution Network Operators (DNOs) appraise requests for connection under near worst-case operating conditions to ensure that customers' quality of supply will not be degraded during normal operation. Typically, worst-case conditions occur with the generator operating at full capacity whilst local load is at a minimum. Here the network experiences the largest reverse power flows and, consequently, the greatest local voltage change which, particularly for rural areas, tends to be the most significant factor constraining generator capacity [5].

Developers and DNOs can make use of several techniques to reduce adverse network impacts arising from potential schemes. These are project specific and depend on the problem at hand. Where a project would result in the violation of equipment thermal or fault level ratings, there is often no alternative to the replacement of affected equipment with new plant of sufficient rating. The voltage rise effect is currently addressed through network and generator operational changes or through asset upgrades. The operational changes include the reduction of primary substation voltage, generator export constraint or operation at leading power factor. Asset upgrades include the reinforcement of circuits or connection at higher voltage levels.

In most cases these measures allow DG connection but they come at a price: operational changes have implications for generator revenue or local quality of supply, while the asset upgrades incur significant capital costs. In particular, the added capital cost can adversely affect the economics of DG projects as current 'deep charging' compels developers to finance the necessary capital expenditure, as a condition of connection. Alternative 'shallow charging' system allow DNOs to fund necessary network upgrades and collect use-of-system charges from DGs (as will be the case in the UK from April 2005). While this lowers developer's upfront costs, the DNO must justify the investment in terms of revenue benefit and this will be reflected in the use-of-system charges levied. Alternative means of accommodating DG that avoid network upgrades have been proposed, including intelligent generator control [6] and active voltage management.

Other than the economic impact of current mitigation measures, the present first-come first-served policy for DG development offers a potential threat to renewable development. Once a Connection Agreement is signed, the developer has guaranteed access rights to the network. Subsequent developments must not impact adversely on the access of the prior connection. This means that an early and sometimes quite minor connection can prevent development of alternative larger sites and ‘sterilise’ parts of the network. The current approach of DG appraisal is generally acceptable for individual connections, where the impact of the generator can be clearly identified and mitigated. However, with larger volumes of developments, not only is impact assessment a major task for DNOs but also that there is an increased risk that first-come first-served development will frustrate efforts to meet Government targets.

### **3 Evaluating Network Capacity**

One of the potential means of improving the situation is for DNOs to issue guidance to developers regarding the existence, or otherwise, of spare connection capacity. To do this, DNOs need to ascertain the capacity of new generation that may be connected to their distribution networks. Recent studies of the transmission network in Scotland have identified where renewable energy could be absorbed by the existing and upgraded transmission system [7]. Performing similar studies on even a small section of the distribution network is relatively more intense and time consuming given the much greater number of possible connection points and the greater influence of voltage, thermal and fault level restrictions.

The simplest analysis follows the approach of current appraisal practice by considering conditions with potential connection at individual locations. Routines developed enable a location-by-location appraisal of available capacity by incrementing power injections until a constraint is violated, defining the maximum capacity. Connection applications that feature generator capacities in excess of these values will require mitigation and perhaps network reinforcement. DG development may occur at adjacent points across whole areas of the network, rather than isolated individual schemes. Analyses for single locations cannot explain potential penetration network-wide as the network is interdependent (e.g., voltage changes at one location alter voltages elsewhere) and non-linear. The number of possible connection points and range of generator capacities means that identifying network capacity over multiple locations is a complex and intensive process, requiring efficient search algorithms.

While a variety of different approaches have been used in distribution-level optimisation problems, the approach followed by the authors was to use proprietary Optimal Power Flow (OPF) software to maximise capacity at specified locations [8]. With DG tending to operate at fixed power factor it was necessary to model DG as negative loads with the capacity of the network evaluated by maximising capacity through load addition (negative load shed). The operation of this ‘reverse load-ability’ technique is explained in detail in [8] and its application is illustrated in the next section.

### **4 Case Study**

The system used in this work is part of the UK transmission and distribution network and serves a load of around 100 MVA in a mainly rural setting. The land mass served has extensive renewable potential and 300 MW of large central generation is sited in the network. To illustrate the techniques developed, a small sub-system is used (Figure 2) involving a section of 132 kV sub-transmission network (grid supply point, bus D), the 33 kV network down to 11 kV primary sub-stations (buses A to C). Furthermore, voltage variations within the full range permitted by UK statute have been allowed ( $\pm 6\%$  at 11 and 33 kV).

Estimates of available capacity at each 11 kV substation in the network were generated by locating negative load at each 11 kV bus (Buses A – C) and executing the OPF. The results for generators at 0.95 lagging power factor at minimum (25%) load levels are shown in Table

1. The available capacity ranges from zero at bus C to over 34 MW at bus B. The constraint on capacity varies between them with bus A limited by the rating on the transformer while buses B and C are constrained by the voltage rise on the 33 kV feeders linking them and the grid supply point D.

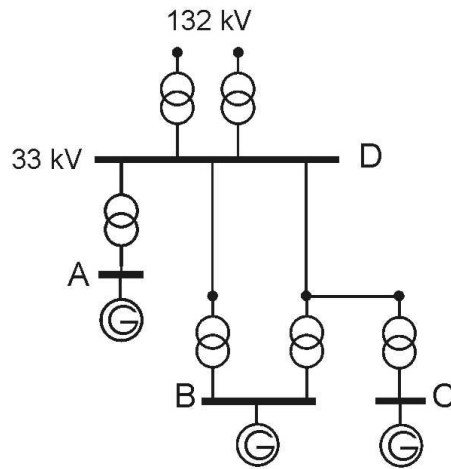

Figure 2: Case study distribution network

The evaluation of capacity presented in Table 1 represents a single analysis at one point in time. As development is resource-led it is unlikely to occur at the locations and in the capacities necessary to fit neatly with these evaluations of capacity. Accordingly, DNOs need to re-evaluate capacity after new connections and project the impact on potential connections either with or without network reinforcement. The ability to evaluate connections in this manner allows planners to consider the downstream impact of connection decisions in terms of the network capacity consumed at each stage in the process. This process can be illustrated very simply using the example above.

Location	Capacity available (MW)
Bus A	8.1
Bus B	34.4
Bus C	0.0
Total	42.5

Table 1: Capacity available for DG connection [8]

The earlier results were for capacity available across the primaries as a whole but, in considering a sequence of developments it is useful to consider capacity available at each primary on its own. In this case, as capacity at bus A is thermally limited, it is essentially independent of the other locations (limited to 8.1 MW). The interdependency of voltage on the feeder to which buses B and C are connected means that the capacity available at each point is dependent on that connected at the other. As the evaluation favours generation at bus B (34.4 MW) to the exclusion of bus C, this represents the maximum available at this bus alone. Bus C's capacity was found by executing the OPF with generation site at bus C alone and indicated an available capacity of 5.1 MW.

The interdependence of buses B and C means that capacity at one must be traded-off against capacity at the other. This trade-off can be demonstrated by siting capacity at Bus C and evaluating the capacity at the others. This situation arises when a developer has received a connection agreement and, as such, possesses prior access rights meaning that any subsequent connections must be considered with the DG in operation. Figure 3 shows the resulting availability of capacity in the network as the prior connected capacity at bus C rises from zero to 5 MW. It is clear that as the prior capacity rises, the available capacity at bus B falls (bus A remains static). More importantly, the reduction in capacity at bus B is greater than the increase at bus C, leading to an overall decrease in capacity connectable. Figure 3 indicates that for every MW of prior capacity at C added there is over 3 MW of capacity lost at bus B; by increasing prior capacity to the maximum 5.1 MW, no potential would then exist at bus B. Evidently, the optimal allocation would be to site nothing at bus C and the maximum amount at B.

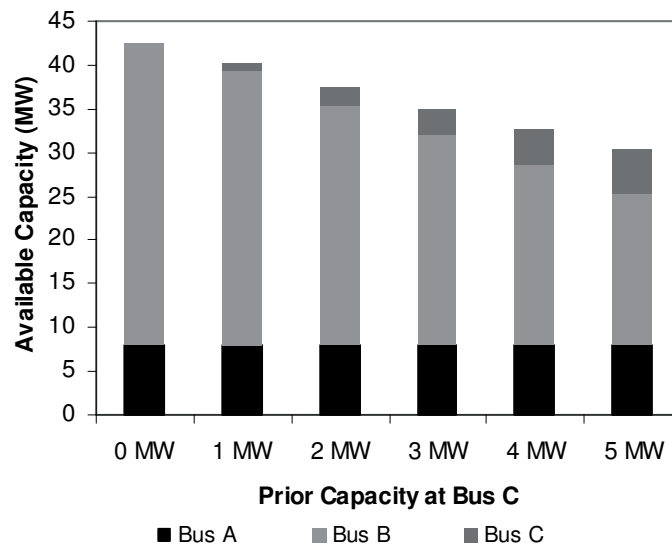

Figure 3: Impact of prior connected capacity at Bus C on available capacity, after [8]

This simple example illustrates the consequences of inappropriately sited connections in terms of their ability to constrain capacity and eventually sterilise the network. This effect, spread across the entire distribution network represents a significant threat to the target of maximising DG penetration to achieve renewable energy targets. Clearly, the ability of DNOs to influence future developments will depend very much on their own internal policies and those of the Regulator towards distribution network access.

## 5 Developing the Method

The OPF-based techniques are a valuable addition to the planning tools potentially available to DNOs. They provide a rapid and objective means of examining connection of DG and will provide information regarding the most suitable sites to connect DG. In addition, they allow the network's limiting factors to be highlighted (e.g. equipment thermal ratings) and it is expected that, together with information contained within the OPF, these could be used to provide an efficient and effective means of determining network upgrades and reinforcement that allow further DG to be accommodated [9].

In the example shown here, only voltage and thermal constraints were respected. While this approach is likely to be reasonably sound for rural feeder systems it is inadequate for assessing urban meshed networks as these will be subject to fault level constraint. Recent work has incorporated fault level restrictions within the OPF technique [10] and work is progressing to incorporate other constraining factors such as transient stability, voltage step

change and harmonic limits. The eventual aim is for a tool that can readily assess available capacity subject to all relevant technical standards.

In [10] the development of bespoke routines allowed the structure of the OPF to be altered such that fixed power factor generators were modelled explicitly. This has allowed further development in the form of incorporating intelligent generator operating strategies into the OPF to assess the impact of widespread local voltage control [11].

## 6 Conclusion

There are a range of technical problems associated with the connection of renewable energy at distribution-level. Further, current connection practices could potentially limit network capability to absorb new renewable energy through the connection of inappropriately sized or located generation. Optimal power flow techniques are demonstrated to be able to assess available network capacity and, potentially, help maximise the connection of renewable generation. The ongoing development of the techniques is also discussed.

## 7 References

- [1] Department of Trade and Industry, *The Renewables Obligation Order 2002*, Stationary Office, 2002.
- [2] Scottish Executive, *Scotland's Renewable Energy Potential – Beyond 2010 : A Consultation Paper*, Aug. 2002.
- [3] Garrad Hassan and Partners Ltd., *Scotland's Renewable Resource 2001*, Scottish Executive, Edinburgh, December 2001.
- [4] N. Jenkins, R. Allan, P. Crossley, D. Kirschen and G. Strbac, *Embedded Generation*, IEE, London, 2000.
- [5] C. L. Masters, "Voltage rise: the big issue when connecting embedded generation to long 11kV overhead lines," *Power Engineering Journal*, vol. 16, no. 1, pp. 5-12, Feb. 2002.
- [6] A.E. Kiprakis, A.R. Wallace; "Maximising Energy Capture from Distributed Generators in Weak Networks", *IEE Proceedings on Generation, Transmission and Distribution*, 151, 05, 611-618, September 2004
- [7] Scottish Executive, *Impact of Renewable Generation on the Electrical Transmission Network in Scotland*, Edinburgh, 2001.
- [8] G. P. Harrison and A. R. Wallace, "OPF evaluation of distribution network capacity for the connection of distributed generation", *IEE Proceedings on Generation, Transmission and Distribution*, 152 (1), February 2005
- [9] P. Vovos, J. W. Bialek and G. P. Harrison , "Optimal generation capacity allocation and network expansion signalling using OPF", Proc. 39th Universities Power Engineering Conference, Bristol, Sept 2004.
- [10] P. N. Vovos, G. P. Harrison, A. R. Wallace and J. W. Bialek, "Optimal Power Flow as a tool for fault level constrained network capacity analysis", *IEEE Trans. Power Systems*, in press.
- [11] P. N. Vovos, A. E. Kiprakis, G. P. Harrison and J. R. Barrie, "Enhancement of Network Capacity by Widespread Intelligent Generator Control", *Proc. 18th International Conference and Exhibition on Electricity Distribution CIRED 2005*, 6-9 June 2005, Turin, Italy.