

Distributed renewable energy systems, such as mini-hydro, can significantly affect the power distribution network. Liberalisation of power markets presents further complications

# Network integration of mini-hydro



**Dr Gareth P. Harrison**

**Aristides E. Kiprakis**

**Dr A. Robin Wallace**

**Institute for Energy Systems**

**University of Edinburgh, UK**

Privately-owned distributed generation (DG) is fast replacing state-owned centralised generation in many liberalised electricity markets. The EU Renewables Directive and national incentives such as the UK Renewables Obligation are encouraging the development of renewables, including mini-hydro. Mini-hydro resources are commonly found in areas with low population and load densities and the capacities of potential new plant means that they will connect to medium or low voltage distribution networks. Historically, the networks in these areas were designed to supply demand that tended to reduce with distance from the transmission system and were operated passively to ensure that the quality of electricity supplied to customers was within statutory limits.

Connection of DG can fundamentally alter the operation of distribution networks. Where DG capacity is comparable to, or larger than, local demand there are likely to be observable impacts on network power flows and voltage regulation. New DG connections must be evaluated to identify and quantify any impact on the security and quality of local electricity supplies. While a range of options exist to mitigate adverse impacts, under current commercial arrangements the developer will largely bear the financial responsibility. The economic implications can make potential schemes less attractive and have restricted the development of DG in liberalised markets.

There are two new techniques that could facilitate a greater capacity of mini-hydro generation. The first allows Distribution Network Operators (DNOs) to determine the capacity of plant that may be progressively connected to their existing system whilst avoiding stranding assets and/or sterilising access. The second describes a means of operating mini-hydro generators to allow more power to be exported to the network whilst maintaining local quality of supply. These techniques may assist the network integration of a greater capacity of mini-hydro both in liberalised markets and in rural areas of less-developed countries.

## **Distribution networks**

Historically, distribution networks were designed to convey electrical energy from the high voltage transmission grid to

consumers supplied at lower voltages. A common feature of distribution networks in rural areas is that they consist of medium to long overhead line circuits (known as radial feeders) extending out to consumers at the most rural edges. As population density and demand for electricity tended to reduce along the feeder, the capacity of the network to supply load could quite reasonably be reduced with increasing remoteness. Accordingly, transformer ratings and conductor cross sectional areas reduce towards the edges of the network and impedance increases. The system was designed and operated on the basis that power flows were uni-directional with active and reactive power moving from the sub-transmission network towards loads. They were also designed on the basis that load patterns, and hence network power flows, were fairly predictable, with daily and seasonal patterns that were well understood. The distribution networks generally operated passively with auto-tap changers on transformers maintaining secondary voltages at pre-set values as loads varied. To compensate for the line voltage drop and to ensure that consumers at the remote end of the network are supplied within statutory voltage limits the DNO will often set the substation voltage a few per cent above the nominal 11 kV. The statutory limits defined in the UK Electricity Supply Regulations, for example, specify that steady-state voltages should remain between  $\pm 6$  per cent of nominal for systems between 1 kV and 132 kV. To ensure this, DNO planners often designed networks to operate over a  $\pm 3$  per cent voltage range.

In the centrally-planned era, consumer demand, losses and contingencies were met by advance scheduling of generation supplying the distribution network via the transmission grid. In the liberalised market, distributed generation can be located geographically to convert renewable or other resources, delivering to the distribution network non-constrainable, intermittent supplies of energy. The connection of distributed generation to the edges of the distribution network results in an operating regime fundamentally different. Depending on the type and rating of the generator, active and reactive power flows can become bi-directional. Furthermore, the development and connection of renewable sources can lead to intermittent, less predictable flows.

## Impacts of DG on the network

The presence of distributed mini-hydro generation can have a number of significant impacts on the operation of the distribution network, including:

- 1 Bi-directional power flow and the potential to exceed equipment thermal ratings
- 2 Reduced voltage regulation and violation of statutory limits on supply quality
- 3 Increased short circuit contribution and fault levels
- 4 Altered transient stability
- 5 Degraded protection operation and co-ordination

### Power flow, thermal ratings, losses

Figure 1, below, shows four scenarios (a-d) for connecting distributed generators to a simple but representative network consisting of a 25 km long, 32 mm<sup>2</sup> copper radial feeder that supplies a local load from a bulk supply point in the sub-transmission network via a 1 MVA transformer. The peak value of the local (rural domestic) load is 400 kW at 0.98 power factor. A series of DG capacities ranging from (a) 0 to (d) 1 MVA (at 0.9 lagging power factor) are connected to the remote end of the feeder.

- a When there is no DG production the local load is supplied entirely from the

transmission network. All equipment operates within thermal limits, and the losses in the overhead line are 19 kW.

- b Where DG production is 300 kW, the power delivered from the transmission network reduces, along with the losses in the feeder. A benefit is that unloading the feeder may allow the DNO to defer network upgrades brought about by future load growth.
- c Where DG production is 600 kW and production exceeds local demand, power will be exported back up the feeder towards the substation and losses increase again, although the line and transformer loadings are still within thermal ratings.
- d If DG production increased to 900 kW the net export back towards the transmission network increases losses beyond their original values. With a generator larger than this and under low demand conditions, the reverse flow may exceed the thermal rating of the transformer or overhead line.

Thermal limitations brought about by increasing DG capacity are usually encountered first in substation equipment such as transformers and switchgear, or at the edges of heavily tapered radial networks where plant capacity is several

Figure 1, below, shows four network scenarios

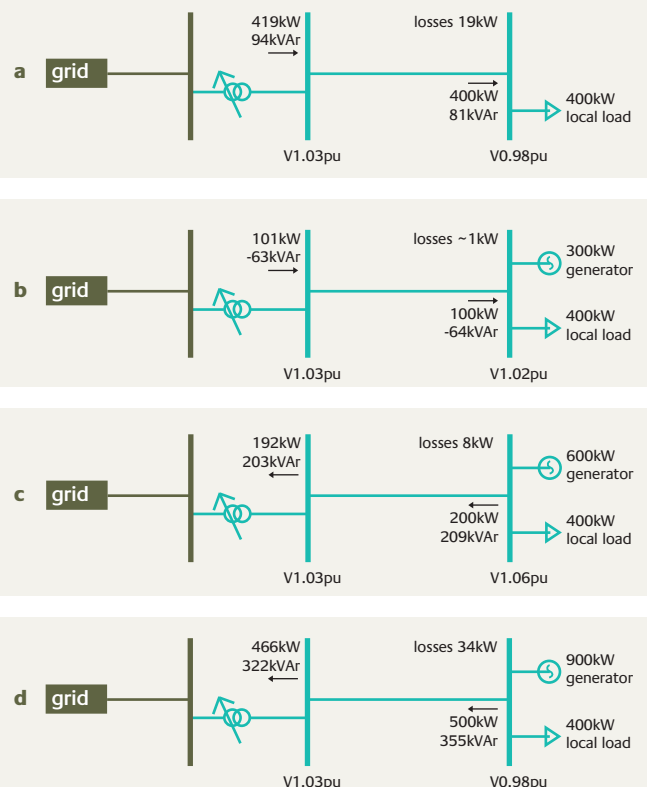

advert

# Network integration

multiples of the local demand. However, it is more frequently the case that voltage violations at the extremities of the network are the first limiting effect.

## Voltage regulation

Power flows along the feeder towards the load will create a voltage drop between the substation and the local load. When the presence of a distributed generator causes the power flow to reverse there will be a local voltage rise at the location of the generator and load. At transmission level, reactive impedance ( $X$ ) is much greater than resistive impedance ( $R$ ), and the voltage excursion is brought about by reactive power flow. However, in the distribution network where  $R$  can be comparable with or exceed  $X$ , the voltage rise is influenced by both active and reactive power flows. Hence, the relatively high line resistance at the edges of distribution networks can restrict active power export from a DG. The network, load and DG capacities shown are once again used to demonstrate the impact of DG on voltage profiles. The local voltages in cases a-d are described below:

- a** With no DG generation the voltage at the local load is 0.98 per unit with the transformer adjusted to establish 1.03 per unit voltage at the substation.
- b** At 300 kW, DG reduces the local demand, the line voltage drop decreases and local voltage rises to 1.02 per unit.
- c** A 600 kW DG reverses power flow and raises local voltage above that of the substation to 1.06 per unit.
- e** A 900 kW DG further increases the voltage rise, leading to a local voltage of 1.10 per unit, well in excess of the statutory limit.

As these cases illustrate, reverse power flow along the feeder determines the voltage rise. When local demand is high and met by DG capacity the voltage rise is reduced. If local demand reduces, say overnight, more DG production is exported to the network and the voltage rise increases. This effect could cause transformer tap-changers (where provided) to operate or over-voltage protection to disconnect the DG. Voltage rise effects can significantly limit the capacity of DG that may be connected to the network in remote rural locations.

## Fault levels

In the event of a short circuit fault on the network all generators will contribute to the fault currents flowing. As such, the switchgear in the DNO network and that of the DG must be rated to withstand the effects of the combined network and DG fault currents. As the point of connection becomes more remote from the transmission network the intervening impedance increases, and the network fault contribution falls. Where connection of the DG would increase fault levels beyond the rating of existing DNO switchgear, it must be replaced.

## Transient stability

The ability of DG to remain connected to the network during transient conditions caused by load changes or network reconfiguration depends on the topography of the network, the nature of the perturbation and the characteristics of the DG. During the transient conditions network stability is reduced. Some DGs can assist in restoring stable conditions and hence it is mutually beneficial for the DNO and developer that such plant should remain connected. Those that cannot may

be disconnected. In terms of overall system stability, current levels of DG penetration are not a concern but this may alter if, as the capacity of renewable energy DG increases it displaces high energy thermal plant that currently ensures stability.

## Protection operation and co-ordination

Prior to the installation of a DG, operation of the distribution network is made safe and reliable by the provision and co-ordination of protection devices at energy sources, switching points or loads. This ensures the integrity and security of supply to consumers based on the traditional operation of the network. The protection schemes were designed and co-ordinated largely for uni-directional flow and their use with bi-directional power flows may lead to unstable or spurious operation. While settings may be adjusted so that protection remains effective during DG operation, it must also be effective when the DG is shut down. The achievement of such a balance may leave the network less closely protected than before, and this must be carefully evaluated

## Connection studies

The impacts that arise from an individual DG scheme are assessed in detail when the developer makes an application for connection. DNOs appraise requests for connection under near-worst case operating conditions to ensure that the quality of supply to their customers will not be adversely affected under all normal DG and network operating scenarios. For instance, studies are carried out assuming that the DG is operating at maximum capacity, but that local load is at a minimum, typically 25 per cent of normal peak demand. These conditions are chosen as they represent the largest reverse power

advert

# network integration

flows and consequently the greatest local voltage change which, particularly for rural areas, tends to be the most significant limitation to the DG capacity.

Where the presence of DG will adversely affect the operation of the DNO network, its impact must be mitigated in a way that encourages development and that is not needlessly punitive, financially, to the developer and the DNO.

## Impact mitigation

There are a number of options open to the DG developer and DNO to reduce adverse network effects arising from a potential mini-hydro generation project and these depend on the initial problem. Where there is the potential to exceed the thermal or fault level rating of equipment then there is generally little option but to replace affected equipment with new plant of higher rating. There is potential for DG and, in particular, mini-hydro plant to benefit the rural network by reducing losses and providing increased reliability, stability and security of supply. However, to extract these benefits, active management of the network would be required along with commercial benefit for the DNO. In any event, the barrier most frequently met and which offers most scope for innovation is maintenance of local voltages within statutory limits. Mitigation strategies include:

- Constraining generator export
- Reducing primary substation voltage
- Importing reactive power
- Conductor upgrading
- Connection at higher voltage

These mitigation measures are discussed with reference to the network illustrated in Figure 1 on page 57 and their effect is demonstrated in Figure 2, above. The analyses do not consider the effects of distance, or intermediate loads. The highest voltage rise shown is that resulting from a 600 kW DG operating at maximum output and at 0.9 power factor, exporting, whilst local load is 100 kW, 25 per cent of maximum. In this case, the voltage exceeds the limit by nearly four per cent.

### Constraining generator export

It is possible to apply load limitation in the turbine governor control system to alter production of active power to avoid network voltage violations. Whilst

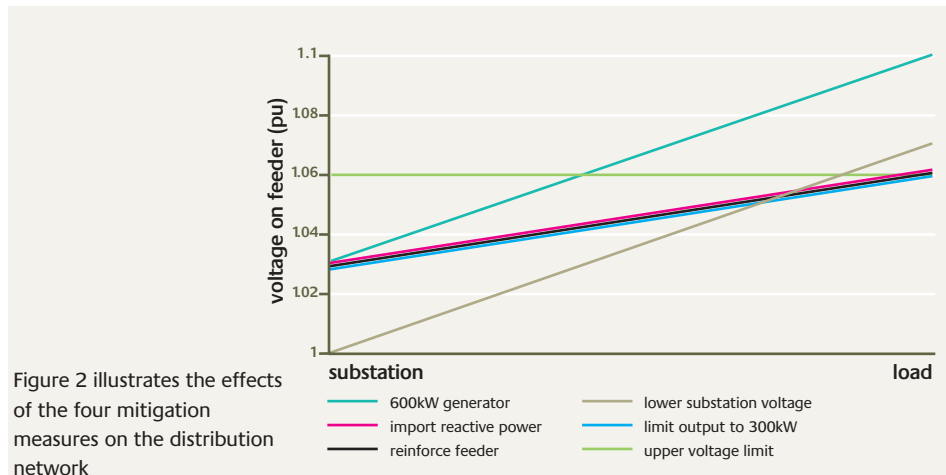

Figure 2 illustrates the effects of the four mitigation measures on the distribution network

effective, this option affects generator revenue and is generally only acceptable where curtailment is likely to be infrequent and where alternatives are costly. Where active power output is limited to 300 kW the voltage remains within limits. This represents the maximum production in the absence of alternative mitigation means.

### Reducing primary substation voltage

Lowering the set-point voltage at the primary substation allows a greater voltage rise before violation. This strategy is shown to shift the voltage profile vertically downwards, but it still does not allow full generator capacity to be exported without voltage violation. Although this may be achieved by setting the voltage set-point to 0.99 per unit, this approach is likely to be prohibited because if generator output decreases (or the DG trips), customer voltages may fall close to or below the lower voltage limit. Intelligent control or active management of simple networks might be employed to restore the depressed voltages, but this may not be practical in large rural systems.

### Importing reactive power

DNOs normally require DGs to export active power at a defined and constant power factor, determined by the network capability to accept or provide reactive power. Synchronous generators may be operated to export or import reactive power and while normally operated to control power factor, they could usefully provide network support by operating in voltage control mode. Standard induction generators can only import reactive power and while this can mitigate the voltage rise, the network must provide the reactive

power. The financial benefits for the developer in exporting more active power could be partly offset by charges imposed by the DNO for the provision of reactive power from the network. In Figure 2 the generator is operated at full output whilst importing reactive power at 0.9 power factor. The voltage gradient and local voltage are reduced significantly.

All of these mitigation techniques are of an operational nature and have consequent implications for DG revenue or local quality of supply. The remaining measures can bring considerable capital costs to the DG development, but result in fewer operational restrictions.

### Conductor upgrading

Replacing existing overhead line conductors with those of greater cross sectional area reduces impedance and limits voltage rise. Unfortunately, the use of any larger and heavier conductors requires the replacement and re-spacing of the support poles or towers to correct the physical profile of the line. As such, this approach can be very expensive. Figure 2 shows the impact of replacing the existing 32 mm<sup>2</sup> conductor with 130 mm<sup>2</sup> copper conductor. It can be seen that voltage rise is significantly reduced and that voltage remains just within statutory limits.

### Connection at higher voltage

At higher voltages a given flow of active and reactive power has a lower current and, as such, the voltage rise is lower. Accordingly, for larger plants that simply cannot connect at lower voltages without violation, the DNO may offer only to connect the DG to the network at the next highest voltage. This may mean the

# network integration

construction of a sub-transmission network switchyard and significant extension of the 33-132 kV sub-transmission system that, inevitably, will be expensive, and therefore may only be feasible for much larger DG schemes.

## Finance and management

Each of the mitigation strategies will have associated costs, either operating costs borne directly by the DG developer, for example production constraints or reactive imports, or capital costs borne by the developer and/or the DNO. As a condition of connection the DNO can insist that the developer finances the expenditure necessary to mitigate adverse impacts. This system is known as 'deep charging' and may add significantly to the capital cost of the project, particularly where line upgrades are involved. In many cases and particularly for smaller projects it may render them uneconomic and limit the penetration of mini-hydro and other renewables. An alternative 'shallow charging' system is being considered where the DNO finances the necessary network upgrading and collects Distribution Use of System (DuoS) charges from generators. However, in this case the DNO must consider carefully whether the volume of renewables and developer commitments could justify the investment.

A further risk to the holistic development of mini-hydro and renewable resources can emerge from the current strategy of developing sites on a first come-first served basis. Currently, a developer's rights to network access are guaranteed once the Connection Agreement is signed. With this guarantee instated, subsequent developments in the same area must not

impact adversely on the access afforded to previously connected DG. This means that an early and sometimes quite minor connection can prevent development of other larger sites in the same area of the network, effectively 'sterilising' areas of the network. If unchecked, this effect can lead to developers rushing to 'bag capacity' and guarantee access.

An opposite effect relates to the equity of investment to upgrade the network. Where a new connection is to be financed by the developer and/or the DNO it is unlikely that it will be designed, specified and installed at the exact capacity of the DG. Design prudence or the use of standard plant ratings may leave spare capacity on a new network modification. While the developer may have agreed to finance this, a subsequent application may be able to access and use the new capacity at a much lower connection charge because the network has already been upgraded. Both issues further complicate and restrict DG development and commend the need for planned and holistic development.

## New approaches to DG

It seems that if the developer or the DNO is prepared to finance, piece-wise, network reinforcement then many of the restrictions to individual network access are reduced or avoided. This is unlikely to lead to full development of the mini-hydro or other renewable resource in a DNO network area. There needs to be a more holistic strategy to develop the network in a way that provides the greatest access to DG within an area for a given level of investment in network infrastructure. Additionally, DG plant that connects to existing or newly reinforced areas of the network ought to be

controlled to make the maximum use of access that is available within the constraints of voltage violation.

## Maximising DG access to networks

Recent studies of the transmission network in Scotland have provided a number of locational signals for the development of renewables that are contingent on significant network investment. They have identified areas where renewable energy could be absorbed by the existing and up-graded transmission network. Not all of the new developments will be deep-connected and most will connect to the sub-transmission or distribution network. Carrying out a similar study on even a small section of the distribution network is more intense and time consuming due to the much greater number of busbars and the greater influence of voltage, thermal and fault level restrictions. To explore holistic expansion of DG access there is a need to determine possible capacity from three types of development within the network.

The notionally simplest approach is a single location-by-location appraisal of the possible DG capacity that could be connected in an area – but in even a small section of the distribution network there may be several hundred busbars. This required the development of a bespoke simulation manager to facilitate control of network power flow analysis software to automate repetitive and otherwise time consuming manual studies. The results of the survey were thereafter more readily obtained but may be optimistic because they do not recognise the effects of prior connections of new DG in the adjoining network.

The number of applications for connection of renewable DG plant and the volume of activity in the UK means that development is a parallel activity. There can many co-lateral applications for access to sometimes different, sometimes identical points within an area of the network. The interdependence of network behaviour and the range of capacities and locations for development means that the determination of overall access is a large multi-dimensional problem not amenable to repetitive simulation. Harrison and Wallace have applied Optimal Power Flow (OPF) techniques, normally used in transmission

Local power demand (PF=0.8)

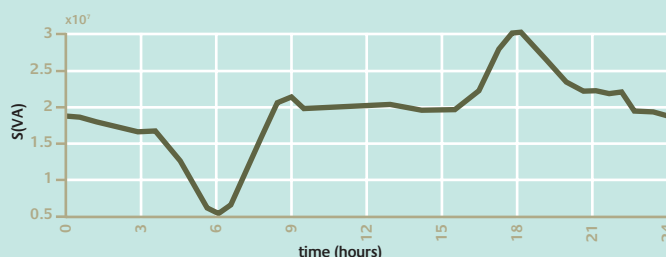
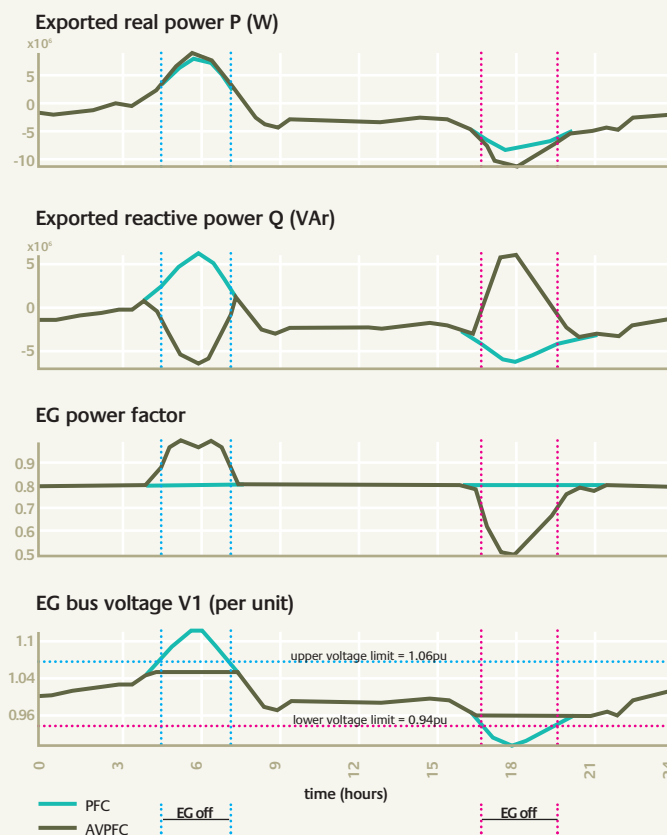

Figure 3, right, illustrates a typical demand profile

Figure 4: showing variations in network power flow and local voltage under power factor (APFC) and hybrid (AVPFC) control schemes.



studies, to determine the maximum simultaneous access for DG plant across some or all network locations selected using the simulation manager. This takes full account of all adjacent development but results in pessimistic totals since locations that may never be sought are maximised unnecessarily.

More realistic use of OPF techniques through the simulation manager enables scenario studies within a selected area of the distribution network. Access to the network and DG development can be modelled sequentially in time and with concurrent multiple developments. This allows not only the determination of maximum connectable capacity but also an investigation of network sterilisation and stranding of assets. These techniques may be used by DNOs, working with developers, to maximise access, clarify the need for network upgrades and avoid network sterilisation or asset stranding.

#### New generator control

Synchronous generators can be operated in either voltage control or power factor control modes. While power factor control used to be obligatory, some DNOs

have permitted voltage controlled operation for DGs at weak parts of the network to provide some voltage support. This has to be evaluated carefully as larger DGs can cause network voltage control systems to operate in response. However, the combination of power factor control together with voltage control of DGs may offer significant benefit to developers if it enables acceptable access to weak areas of the network and allows continuous operation of the plant when co-ordinated with varying local demand.

Wallace and Kiprakis have developed a hybrid voltage/power factor control algorithm that combines the features of both methods. Its normal mode of operation is to export power at a pre-defined and constant power factor. However, once the local voltage exceeds a threshold, that lies within the statutory limits, the controller smoothly transfers to voltage control to hold voltage within these limits. Once conditions change and allow the voltage to fall, power factor control resumes. The controller enables greater export during low demand periods and can also provide voltage

support at times of high demand.

Extensive simulations have compared operation of a water-turbine driven synchronous generator using a typical power factor control system and with the new hybrid scheme. Figure 4, left, shows the resulting variations in network power flow and local voltage under power factor (APFC) and hybrid (AVPFC) control schemes. There are a number of observations regarding operation in power factor control mode. Firstly, the voltage would rise above the upper statutory limit during the period of low demand, and in consequence the generator would be disconnected with significant loss of generation. Secondly, between 1630 and 1930 excessive local demand would draw voltage below the lower voltage limit. Under-voltage protection would disconnect the DG causing the voltage to fall further and in the absence of available voltage controls the DNO would draw more power from the sub-transmission system. Under hybrid control, however, the voltage is continuously maintained within limits, allowing the generator to stay connected.

#### Conclusions

The connection of mini-hydro and other renewable generation to the distribution network creates a range of impacts that must be limited to protect security and quality of supply. Mitigation techniques currently employed may add significant costs and deter investment in DG plants. The inappropriate siting of new generation, or poorly phased development can lead to the sterilisation of an entire area of network and lowers the opportunity for developing surrounding potential without network upgrades. Extensive development of renewables will require a more holistic approach to network infrastructure.

#### Biography

Dr Gareth Harrison, Aristides Kiprakis and Dr Robin Wallace are with the Institute for Energy Systems, School of Engineering & Electronics, University of Edinburgh, Edinburgh, U.K.

The authors acknowledge with gratitude support provided by EPSRC (research grant number GR/N04744). For more information and references please contact the authors on: (+44) 131 650 5583 or email Gareth at: email: Gareth.Harrison@ee.ed.ac.uk