

# Centralized and Distributed Voltage Control: Impact on Distributed Generation Penetration

Panagis N. Vovos, Aristides E. Kiprakis, A. Robin Wallace and Gareth P. Harrison, Member, IEEE

**Abstract**—With the rapid increase in distributed generation (DG), the issue of voltage regulation in the distribution network becomes more significant and centralized voltage control (or active network management) is one of the proposed methods. Alternative work on intelligent distributed voltage and reactive power control of DG has also demonstrated benefits in terms of the minimization of voltage variation and violations as well as the ability to connect larger generators to the distribution network. This paper uses optimal power flow to compare the two methods and shows that intelligent distributed voltage and reactive power control of the DG gives similar results to those obtained by centralized management in terms of the potential for connecting increased capacities within existing networks.

**Index Terms**—dispersed storage and generation, optimal power flow, power generation control, power distribution planning, voltage control.

## I. INTRODUCTION

CONNECTION of distributed generation (DG) fundamentally alters distribution network operation and creates a variety of well-documented impacts with voltage rise being the dominant effect, particularly in rural networks [1]. A range of options have traditionally been used to mitigate adverse impacts but these generally revolve around network upgrades, the costs of which may be considerable. This occurs partly as a result of current Distribution Network Operator (DNO) practice of assessing DG connections on a ‘first come-first served basis’ as well as the ‘fit and forget’ approach to DG operations which require DG to operate at fixed power factors with capacity limited to minimize adverse impacts. These effects conspire to limit the capacity available within distribution networks to connect DG. However, a range of alternative operational approaches have been proposed to raise the level of DG capacity that may be accommodated within networks whilst limiting the need for capital investment in new network assets.

Active management, a form of centralized control of distribution networks, has been proposed as a means of enhancing connectable capacity [2]. Taking a similar approach to that used in transmission systems, a distribution management system controller would be used for wide area voltage control and reactive power management [3]. It would

employ state estimation to assess voltage profile and dispatch DG and other network elements accordingly [4]. The approach also requires investment in sensors and communication assets.

An alternative approach of ensuring maximum capacity with minimal voltage impacts is through use of distributed, ‘intelligent’, power factor and voltage control of DG and other network components such as transformers with on-load tap changers (OLTCs). Previously published work [5] demonstrates the benefits in terms of the minimization of steady-state voltage variations (and violations) as well as the ability to connect larger generators to the distribution network. While the capacity benefit could be easily quantified for individual DGs, the advantage of widespread usage of intelligent distributed control of DG has not been explored fully.

The aim of this paper is to compare the centralized and distributed approaches for controlling distribution network voltages in terms of the capacity of DG that could be accommodated within existing networks as well as contrasting them with the current power factor control approach. To achieve this it was necessary to draw on earlier work [6]-[8] that used optimal power flow (OPF) techniques to evaluate the network capacity available for connecting distributed generators. The technique has been extended to incorporate the intelligent generator control algorithms and in doing so could find the maximum level of DG penetration possible in each case.

The paper is set out as follows: Section II explores the theoretical basis of the voltage variation and the potential methods of control. Section III sets out the OPF method and the necessary augmentation required to incorporate the two voltage control techniques. Sections IV and V deal, respectively, with a case study while Section VI discusses the implications of the results.

## II. THEORY

### A. Voltage Variation in Weak Networks

Traditionally, DNOs required that all distributed generators connected to the distribution network should operate in Power Factor Control (PFC) mode. However, PFC has an adverse effect on generator terminal bus voltage, especially in the case of weak distribution networks. Fig. 1 illustrates the simplest form of an electrical network that consists of 2 buses connected through a single line.

Manuscript revised June 22, 2006.

The authors are with the Institute for Energy Systems, Joint Research Institute for Energy, School of Engineering & Electronics, University of Edinburgh, Edinburgh EH9 3JL, UK, (emails: Aristides.Kiprakis@ed.ac.uk, panaghsg@gmail.com, Gareth.Harrison@ed.ac.uk, Robin.Wallace@ed.ac.uk).

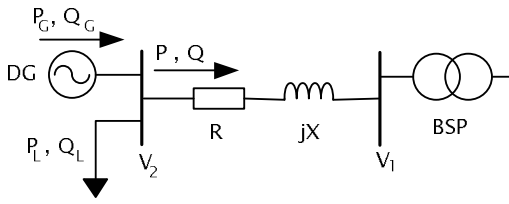

Fig.1. Simple two-bus system.

The voltage drop  $\Delta V$  across the line is approximated by the equation:

$$V_1 - V_2 = \Delta V = R \cdot P + X \cdot Q \quad (1)$$

where  $R$  and  $X$  are the line resistance and reactance respectively, and  $P$  and  $Q$  the active and reactive power exported from the DG bus towards the Bulk Supply Point (BSP). Any fluctuation in real power brings about a proportional fluctuation of voltage. This is particularly evident in cases of weak networks where the line resistance is high relative to its reactance. In power factor control mode the  $P/Q$  ratio is maintained constant, so  $Q_G$  follows any variation of  $P_G$ , tending to augment the voltage variation. It is for these reasons that voltage rise is regarded as one of the major impacts of, and constraints on, the connection of new DGs on the network, particularly in rural areas [1].

In (1), if  $Q$  was allowed to compensate for the feeder voltage rise or drop created by  $P$  by adjusting in the opposite direction (with  $P$ ), then voltage  $V$  could be maintained within limits allowing greater active power export. For voltage rise, this would be achieved by defining a more leading power factor at which the generator is to be controlled. Power factor settings could be specified so that DG operates at lagging power factor to export reactive power during high demand periods whilst importing during low demand. While this appears to be a relatively simple approach, it would require analysis to ensure that voltage is maintained appropriately under all normal operation cases and may require a degree of central coordination.

### B. Voltage Regulation or Power Factor Control

Distribution Network Operators have hitherto been reluctant to allow any operation by independent generators, which could potentially disrupt the passive role of the distribution network to supply demand. Specifically, distributed generators are not permitted to perform Automatic Voltage Regulation (AVR), an inherent feature of synchronous generators to regulate the terminal bus voltage by adjusting their reactive power output, as it may destabilize the automatic on-load tap changers (OLTCs) of some distribution transformers. A further reason for the avoidance of AVR in most distributed generation applications is that should a small generator with AVR control attempt to correct for voltage drops, it has to inject great amounts of reactive power in order to raise the bus voltage. This may result in high field currents and overheating for the generator, triggering the excitation limit or over-current protection and disconnecting the generator from the network.

For the above reasons most distributed generators have been

required by the DNOs to operate in power factor control mode. PFC is less disruptive for network voltage control devices such as OLTCs and results in much lower field currents brought about by voltage drops under AVR control, thereby reducing thermal stresses on the generator [9].

### C. Alternative Voltage Control

#### 1) 'Intelligent' Distributed Voltage/Power Factor Control

Kiprakis and Wallace [5] proposed a voltage control method for DGs, which assumes a more flexible attitude from DNOs concerning the voltage control by DGs. The authors' target was to develop a voltage control method capable of keeping the DGs online during light or heavy demand conditions by combining the advantages of AVR and PFC. The method was termed Automatic Voltage / Power Factor Control (AVPFC) and its steady-state response has the effect of relaxing power factor when voltage approaches the statutory limits. Its operation is depicted in the vector diagram of Figure 2.

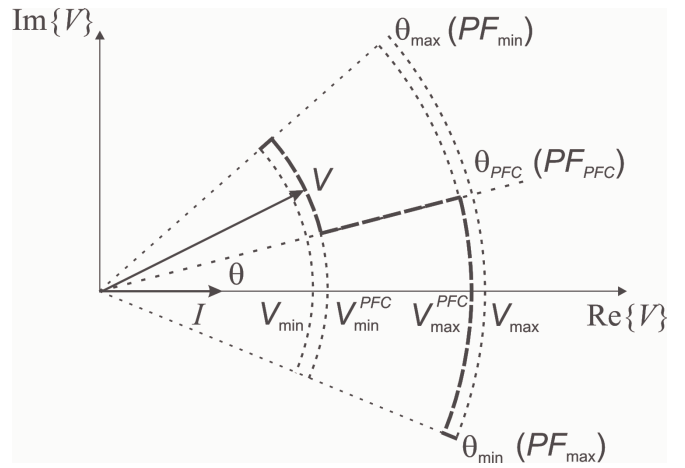

Fig.2. Vector diagram of the generator voltage and current showing the response of the 'intelligent' distributed controller.

The operating point of the generator (tip of vector  $V$ ) always moves along the thick, dashed line. When voltage approaches the statutory limits,  $V_{\min}$  or  $V_{\max}$ , the PFC is deactivated and the DG adjusts the production of reactive power to support voltage. The generator decreases the  $P/Q$  ratio when voltage drops to the lower threshold,  $V_{\min}^{PFC}$ , while it increases the  $P/Q$  ratio when voltage reaches the upper threshold  $V_{\max}^{PFC}$ .

Obviously, in altering the  $P/Q$  ratio, the power factor is also being changed: it must be restricted between the minimum ( $PF_{\min}$ ) and maximum ( $PF_{\max}$ ) operating power factors.

The major advantage of this approach is that it does not require knowledge of the distribution network as a whole, relying purely on the voltage signals at its own terminals. As such, the approach would not require extensive deployment of sensors and communications equipment and the 'intelligence' can be embedded within the DG control system. However, the controllers would need to be set up such that they did not conflict with others, e.g., by causing hunting.

## 2) Centralized Voltage Control

Theoretically, voltage control of the distribution network can be achieved centrally, in a similar manner to the transmission system through dispatch of active and reactive power from distributed generators and other network elements.

Such an active management scheme would consist of a distribution management system controller accepting voltage, power flow and equipment status measurements at selected locations in the distribution network. The controller would then use state estimation to estimate network power flow and voltage profiles before dispatching plant according to economic dispatch from optimal power flow [4] or a rule-based method.

The downsides to the approach include the necessary investment in sensors, communications and dedicated controllers as well as the balance required to ensure adequate accuracy of the state estimator.

## III. SIMULATION TECHNIQUE

### A. Optimal Power Flow as a Tool for Capacity Allocation

While optimal power flow (OPF) is traditionally used as an operating tool in power systems, Harrison and Wallace [6] presented a means of using it to assess the availability of network capacity to accept DG. The approach arose as a means of allowing DNOs to guide developers to appropriate locations and avoid ‘sterilization’ of the network or expensive upgrades. With an increasing number of DG connections their impacts become increasingly interdependent and OPF presents a reliable means of dealing with this aspect.

The approach set out in [6] represented DG as negative load and employed the load-shedding algorithm in a proprietary OPF to maximize DG capacity such that network voltage and thermal constraints were respected. It was successfully able to demonstrate the consequences for available capacity when a small generator was located inappropriately. With the network constraints limited to voltage and thermal limits, the approach was suitable for rural networks but it had limited applicability in urban networks within which fault level constraints may predominate. This shortcoming was addressed in [7], where Vovos *et al.* presented a bespoke OPF that explicitly represented DG capacity as generators as well as developing a method for incorporating the constraints imposed by the fault level capability of switchgear. This aspect was developed further in [8] with fault level constraints incorporated directly into the OPF formulation as simple non-linear inequality constraints resulting in much greater accuracy and speed. Both [7] and [8] showed that the additional constraints had a significant impact on the ability of the network to accept new DG. The following outline of the method is based broadly on the formulation in [7] and [8].

#### 1) New distributed generation capacity

At each location where DG may be connected (termed ‘Capacity Expansion Locations’ in [7] and [8]) the available DG capacity is simulated as a generator with quadratic cost functions. This formulation is subtly different to traditional

OPF as here the functions have negative coefficients to indicate that development of DG results in a negative cost or, in other words, a benefit. As such, DG with larger coefficients (i.e., more negative) will be favoured which allows locational preferences to be expressed, although it is generally assumed [6]-[8] that these are the same for all new DG in order to avoid biasing the analysis.

A key requirement for the approach is that the operating capability of the DG must ‘grow’ with the capacity rather than being fixed like traditional generator models in OPF. In the case of power factor controlled-DG, new capacity has constant power factor (normally between 0.9 and unity) including those interfaced via inverters [10].

#### 2) Capacity benefit model

The target of the optimization procedure is to maximize the benefit from new generation capacity for the DNO. This is consistent with electricity regulators acknowledging the positive effect of DG with, for example, the UK regulator, Ofgem, providing localized monetary incentives to DNOs to encourage them to connect DG to their networks [11]. The total benefit from new capacity  $P_g$  across all candidate buses forms the following quadratic objective function  $f$ :

$$f = \sum_g C_g (P_g) = \sum_g (a \cdot P_g^2 + b \cdot P_g + c) \quad (2)$$

where  $a$ ,  $b$ , and  $c$  are the coefficients of the quadratic benefit function and are negative. DG capacity is always positive and  $C_g$  is the benefit for the DNO from a new generator per unit capacity connected at bus  $g$ . The use of this formulation is necessary as by minimizing negative costs DG capacity and benefit is maximized.

#### 3) Transmission network

The energy transfers to and from the higher voltage transmission network or with adjoining distribution systems are simulated as generators with quadratic cost functions. The coefficients of the cost functions are negative for exports and positive for imports. The outputs of the generators are negative when they represent exports and positive when they represent imports.

#### 4) Existing capacity and loads

Existing generation capacity is simulated as generators with constant active power output, equal to their maximum capacity, and given reactive power injection capabilities. Loads are simulated as sinks of constant active and reactive power.

#### 5) Network constraints

The network must be operated within a narrow range of voltage to ensure safe operation of power system equipment and quality of supply:

$$V_b^{\min} \leq V_b \leq V_b^{\max} \quad (3)$$

where  $V_b^{\min}$  and  $V_b^{\max}$  are the lower and upper bounds of the voltage  $V_b$  of bus  $b$  around the rated value.

The thermal capacity of a line or transformer,  $t$ , also sets a limit to the maximum apparent power (MVA) transfer:

$$|S_t| \leq S_t^{\max} \quad (4)$$

where  $S_t$  is the apparent power and  $S_t^{\max}$  is the thermal limit.

The connection of DG raises network fault currents at all network locations with the impact being dependent on generator impedance and bus voltages. In [8], these effects are considered by relating the additional impedance introduced into the impedance matrix to the MVA capacity of the DG. The fault level constraints given by the fault capacity,  $I^{cap}$ , of each set of switchgear at bus  $b$ :

$$\left| I_b^f \right| \leq \left| I_b^{cap} \right| \quad (5)$$

### B. Enhanced OPF for Alternative Voltage Control

The formulation in the preceding section is directly applicable for determining network capacities where the generator is operated in power factor control mode. This section shows the necessary enhancements to the OPF formulation in order to allow analysis of the effect of the distributed and centralized voltage control schemes.

With the benefit function (2) associated purely with DG capacity, the voltage control scheme employed will only influence the objective function through the amount of DG connectable. As such, the approach is capable of encapsulating the impact of different voltage control schemes on the benefit from new generation capacity. Furthermore, the mathematical description of the contribution of DGs to fault levels is common for all voltage control schemes.

The main difference in the OPF formulation between DGs operated under power factor control (PFC) and the distributed or centralized voltage control schemes is that power factor is allowed to vary, within the DG operating limits, when voltage drops or rises beyond a critical threshold value. Since the focus is on capacity planning it is logical to expect that new capacity will only raise voltage levels. Thus, in order to simplify the analysis it is assumed that the power factor constraint is relaxed only when the generator voltage  $V_G$  rises to a critical value  $V_{threshold}$ . In addition, in order to consider both leading and lagging power factors the angle  $\theta_G = \text{sign}(PF) \cdot \cos^{-1}(PF)$  is constrained rather than the power factor ( $\text{sign}(PF)$  is positive for lagging and negative for leading power factors).

Finally, the minimum  $PF_{min}$  and maximum  $PF_{max}$  operating power factors are roughly the same for various sizes of DGs. Therefore, it is assumed that  $PF_{min}$ ,  $\theta_{min}$ ,  $PF_{max}$ , and  $\theta_{max}$  are common for all new DGs. Furthermore,  $PF_{max}$  is usually the rated power factor (generation at rated output), so it is usually the target  $PF_{PFC}$  of PFC. Both assumptions can be described in the OPF formulation. Firstly, the constraints for an allowed range of power factor:

$$PF_{min} < PF_G < PF_{max} \Rightarrow \theta_{min} < \theta_G < \theta_{max} \quad (6)$$

and for power factor controlled DG:

$$PF_{max} = PF_{PFC} \Rightarrow \theta_{max} = \theta_{PFC} \quad (7)$$

#### 1) Distributed voltage control

The voltage control strategy of the distributed voltage controller is described by the curve in the voltage-reactive power graph in Figure 3.

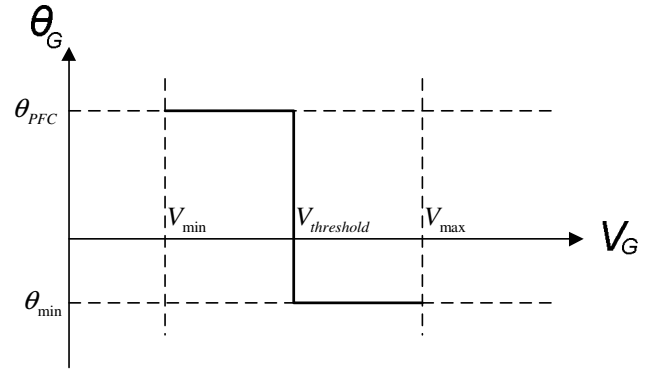

Fig. 3. Distributed voltage control strategy.

Equation (8) describes this control strategy mathematically:

$$\begin{aligned} \theta_G &= \theta_{PFC} && \text{when } V_{min} \leq V_G < V_{threshold} \\ \theta_{PFC} < \theta_G \leq \theta_{min} &&& \text{when } V_G = V_{threshold} \end{aligned} \quad (8)$$

In order to avoid the optimization burden that the discrete transition between power factor and voltage control creates, Equation (8) is approximated by the equality constraint below which represents the sigmoid function in Figure 4:

$$\theta_G = \vartheta_{eq} \Rightarrow \tan^{-1}(Q^G/P^G) = A + K \cdot \tan^{-1}(B \cdot V_G + C) \quad (9)$$

where the functions  $A$ ,  $B$ ,  $C$  and  $K$  are defined in the Appendix. This approximation creates a smooth transition around  $V_{threshold}$  for  $\theta_G$  with respect to  $V_G$ .

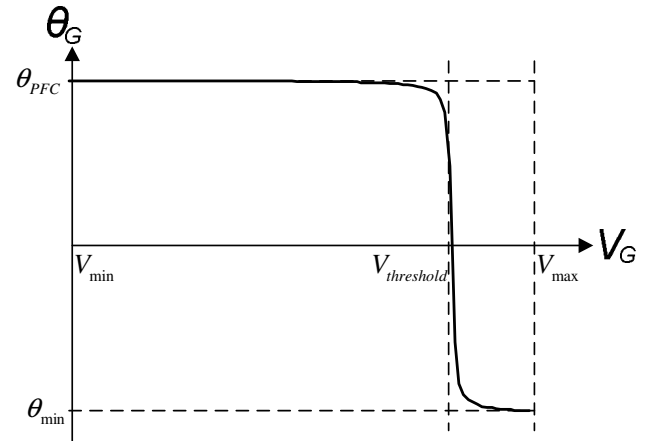

Fig. 4. Smoothing of control strategy transition

#### 2) Centralized voltage control

When DGs are centrally dispatched, their voltage control region is restricted only by their PF operating limits and the statutory voltage regulations:

$$PF_{min} < PF < PF_{max} \Rightarrow \theta_{min} < \theta_G < \theta_{max} \quad (10)$$

$$V_{min} \leq V_G < V_{max} \quad (11)$$

Constraints (10) and (11) are shown graphically in Figure 5.

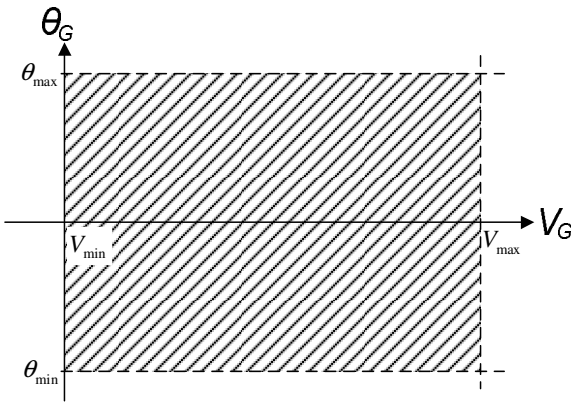

Fig. 5. Central voltage control region of DGs.

IV. TEST CASE

A. Network Topology

The generic 12-bus 14-line distribution network presented in Figure 6 has three potential DG connection points at buses 1, 10 and 11 [7]-[8]. Connected to the 132 kV system at Bus 12, the network has a common rated bus voltage level at 33 kV, except for the load buses which are at 11 kV. The connection points are connected to the 33 kV network through 30 MVA 33:11 kV transformers, with taps operated fixed for simplicity. The automatic tap changer on the 90 MVA 132:33 kV transformer is enabled to operate in voltage control mode and regulate within  $\pm 2\%$  of the rated voltage at the low voltage side within a  $\pm 10\%$  tap range. The characteristics of transformers and lines are presented in Table I. The loads on buses 1, 3, 5, 6, 8, 10 and 11 are assumed to be drawing constant complex power. A pre-existing 15 MW generator is installed on Bus 5, capable of providing up to 10 MVar of reactive power.

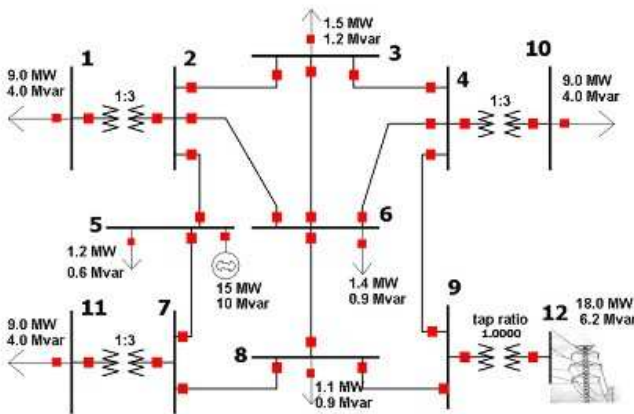

Fig. 6. 12-bus 14-line test network [7], [8]

B. Constraints

Line 2-5 is constrained by a thermal limit of 14 MVA, 4-9 by a thermal limit of 40 MVA, while all other lines are considered to be unconstrained. Up to 100 MW of active and

60 MVar of reactive power can be exchanged with the 132 kV external network without affecting secure operation. Finally, bus voltage fluctuations were limited to  $\pm 10\%$  around the nominal values. Switchgear is rated at 250 MVA at 11 kV, 1,000 MVA at 33 kV and 3,500 MVA at 132 kV, which are typical UK ratings [12].

TABLE I  
BRANCH CHARACTERISTICS FOR THE 12-BUS NETWORK [7]

Bus		R (pu)	X (pu)	MVA	Type
To	From				
1	2	0	0.3	30	T
2	3	0.48	0.3	$\infty$	L
2	5	0.24	0.15	14	L
2	6	0.72	0.45	$\infty$	L
3	4	0.64	0.4	$\infty$	L
3	6	0.64	0.4	$\infty$	L
4	6	0.48	0.3	$\infty$	L
4	9	0.66	0.35	40	L
4	10	0	0.3	30	T
5	7	0.688	0.43	$\infty$	L
6	8	0.768	0.48	$\infty$	L
7	8	0.56	0.35	$\infty$	L
7	11	0	0.3	30	T
8	9	0.768	0.48	$\infty$	L
9	12	0	0.1	90	T

C. Voltage Control Properties

The rated power factor of each DG is assumed to be 0.9 lagging. The distributed and centralized voltage control strategies allow relaxation from this value within the range of 0.9 lagging and 0.9 leading. With distributed voltage control, the power factor is allowed to vary once the generator voltage reaches  $V_{threshold}$ .

D. Economics

The UK energy regulator Ofgem set an incentive for DNOs for connecting DG of £1.50/year for each new kW of DG. This represents the capital expenditure component of the incentive [11] and is used as the marginal benefit, coefficient  $b$ , in Equation (2). In this specific case, the other coefficients,  $a$  and  $c$ , are not required and are therefore set to zero.

V. SIMULATION RESULTS

Two sets of analyses were performed for each of the three voltage control modes. The first set includes the network voltage and thermal constraints as a proxy for a rural network, while the second set aims to represent a more urban network by including the fault level constraints.

The initial capacity allocation for the ‘rural’ version of the network (i.e., with fault level constraints ignored) is presented in Table II. It is clear that power factor control results in the lowest total new capacity and export to the 132 kV network while the more relaxed operating modes offer greater connectable capacity. It is intuitive that the broader the operating voltage region of the generators (see Figures 3 and

5) the broader the solution space for the OPF. Consequently, the benefit the DNO receives for connecting DG (i.e. the objective function) increases as the control over power factor is relaxed. Distributed and centralized voltage control, respectively offer 72 to 86% gains in connectable capacity and corresponding financial gain for the DNO. However, the impressive total capacity achieved from the methods with relaxed power factor comes at a cost: that of high losses which are between 4.8 and 5.8 times greater than with PFC. High losses have previously been suggested as an outcome of active (centralized) voltage control [13].

The high losses are due to a combination of increased active power export from the generators and their operation at more leading power factors (increased reactive power imports) to regulate local voltage levels. The action of the two voltage control techniques is clearly shown by inspecting the power factors of the DG at each location: in all cases these have become more leading to hold the voltage down by absorbing reactive power.

TABLE II  
OPTIMAL CAPACITIES WITH FAULT LEVEL CONSTRAINTS IGNORED

	PFC	Intelli-Gens	Cen-Gens
<b>Bus 1 capacity (MW) and [power factor]</b>	8.3 [0.90]	16.0 [-0.94]	22.8 [-0.90]
<b>Bus 10 capacity (MW) and [power factor]</b>	23.3 [0.90]	32.2 [1.00]	31.5 [0.95]
<b>Bus 11 capacity (MW) and [power factor]</b>	13.8 [0.90]	29.7 [-0.95]	30.0 [-0.96]
<b>Total DG capacity (MW)</b>	45.3	77.9	84.2
<b>Export (MW)</b>	25.2	38.6	40.7
<b>Losses (MW)</b>	4.0	23.2	27.1
<b>Capacity benefit (£/year)</b>	69,242	119,027	128,201

In the second set of analyses for the ‘urban’ version of the network it became clear that connecting DG in the capacities suggested in Table II would violate the breaking capacity of the switchgear connected to buses 1 and 10. When fault levels are included as a network constraint the overall level of connectable capacity alters (Table III) with reductions in overall capacity of 3.5%, 8.5% and 12%, for PFC, distributed and centralized voltage control, respectively. Due to the proportionately larger impact on the voltage control schemes the relative capacity improvement over PFC reduces to 63% for distributed control and 70% for centralized. The financial impact for the DNO is that benefits would be reduced by between £2,500 and £15,500.

The balance of capacity between the locations also alters. For power factor control, the effect of relieving fault level constraints is to re-allocate all capacity from bus 1 to the other locations. With the other two control schemes, it is Bus 10 that suffers reductions in capacity with bus 1 accepting much of the additional capacity.

The power factors of each DG highlight the active constraints on capacity at each location. For Bus 10 the power

factor remains at 0.9 lagging under both distributed and centralized voltage control. This implies that there is no voltage rise problem requiring control action at the capacities indicated, i.e. that fault levels are the binding constraint.

The impact on network losses is more complex in this case with all but distributed control seeing modest reductions, consistent with the decrease in total capacity. With distributed voltage control the losses actually increase as a result of greater capacity being located at Bus 1 which is electrically remote from the 132 kV network. This raises questions regarding the extent of the net benefit (in energy terms) that arises from increasing the installed capacity within a weak distribution network. It is possible that by increasing DG capacity in such a system, the losses would be dramatically increased causing the net MW delivered to decrease below the levels experienced when pure PFC is utilized. This would imply that the increased losses would have to be partially covered by central generation. Hence, increased DG would have a negative impact to the energy balance of the system.

TABLE III  
OPTIMAL CAPACITIES WITH FAULT LEVEL CONSTRAINTS INCLUDED

	PFC	Intelli-Gens	Cen-Gens
<b>Bus 1 capacity (MW) and [power factor]</b>	0.0 [N/A]	32.5 [-0.98]	27.5 [-0.90]
<b>Bus 10 capacity (MW) and [power factor]</b>	28.3 [0.90]	6.8 [0.90]	12.4 [0.90]
<b>Bus 11 capacity (MW) and [power factor]</b>	15.5 [0.90]	32.0 [-0.97]	34.2 [-1.00]
<b>Total DG capacity (MW)</b>	43.7	71.3	74.1
<b>Export (MW)</b>	16.5	28.7	31.0
<b>Losses (MW)</b>	3.9	26.4	26.7
<b>Capacity benefit (£/year)</b>	66,754	108,853	112,704

## VI. DISCUSSION

There are two areas of interest here: the relative merits of the distributed and centralized control schemes and the losses.

### A. Distributed or Centralized?

It is clear from the results that both voltage control schemes have a major impact on the potential penetration of DG. It is also interesting to note that while the centralized control scheme delivers greater DG penetration the difference is restricted to 4 to 8% across the two cases. There is also a more significant impact on ‘rural’ networks which is intuitively correct given the predominance of voltage rise in such networks and the fact that they would benefit most from voltage control. It is clearly in the interest of DNOs to consider means of raising the penetration of DG, particularly when they benefit financially.

The focus in this paper has been on voltage control and the benefits in terms of improving DG penetration. A significant issue for comparing the two competing approaches is the costs and risks associated with them. In particular this includes the upfront costs associated with the centralized, active

management, approach. Further work is required to provide a thorough cost benefit comparison of the two approaches to distribution network voltage management. Other areas requiring attention would be to explore the network performance with additional active network elements, OLTCs, SVCs under distributed or centralized control of active and reactive power and voltage.

### B. Losses

With DNOs in the UK now incentivized to manage losses as a means of improving economic efficiency and environmental impact [11], there would be concern over the increase in losses suggested here. The incentive scheme sees DNOs rewarded for losses below and penalized for higher than a historic loss benchmark value. With benchmark losses in this example calculated to be 2 MW, a loss incentive of 3p/kWh suggests that DNOs would face an hourly penalty of £60, £636 and £753 for power factor, distributed and centralized control, respectively.

Given that loss penalty per hour is far in excess of the yearly benefit the DNO receives for connecting DG capacity (£1.50/year) it was deemed useful to consider how the DNO might locate DG when the loss incentive was taken into account and what effect this would have on the relative performance of the voltage control schemes. To do this the OPF formulation was enhanced to include losses. The original capacity benefit function (2) was restated to account for the incentive,  $W_L$  (3p/kWh), provided by the difference between actual,  $P_{lines}^{losses}$ , and benchmark losses,  $P_{BM}^{losses}$

$$f' = \sum C_g(P_g) - W_L [P_{BM}^{losses} - P_{lines}^{losses}] \quad (12)$$

The OPF was run with this new objective function for each of the earlier control methods and with and without fault level constraints. With the results being identical whether fault levels were included or not, Table IV contains the results from the OPF.

TABLE IV  
OPTIMAL CAPACITIES CONSIDERING LOSS INCENTIVE

	PFC	Intelli-Gens	CVC-Gens
<b>Bus 1 capacity (MW) and [power factor]</b>	2.2 [0.9]	1.8 [0.9]	1.8 [0.9]
<b>Bus 10 capacity (MW) and [power factor]</b>	15.8 [0.9]	16.1 [0.91]	16.4 [0.93]
<b>Bus 11 capacity (MW) and [power factor]</b>	7.5 [0.9]	7.5 [0.9]	7.5 [0.9]
<b>Total DG capacity (MW)</b>	25.5	25.4	26.7
<b>Import (MW)</b>	-8.6	-8.7	-8.9
<b>Losses (MW)</b>	0.7	0.7	0.7
<b>Capacity benefit (£/year)</b>	38,905	39,146	39,409
<b>Losses benefit (£/year)</b>	214,720	214,648	215,373

What is immediately clear from Table IV is that apart from minor differences in power factor and the corresponding

impact on imports and benefits values, all three cases allow the same combination of DG capacities. The capacity connectable is around 60% of the original amount under power factor control. The strength of the loss reduction incentive appears to be such that the benefits of voltage control would not be recognized.

Clearly as the analyses have been carried out under conditions of maximum generation and minimum load the maximum possible reverse power flows are captured under these circumstances. As such, the power losses and correspondingly the hourly financial penalties are overstated as load will be larger at all other times. This clearly represents the worst case scenario in terms of DG penetration. Further work is required into the balance between DNO incentives to reduce losses and those for connecting distributed generation.

## VII. CONCLUSIONS

If DNOs move away from strict power factor control of distributed generation the remaining capacity in the existing network can be better exploited. Intelligent distributed and centralized voltage control methods offer significant gains in connectable capacity, particularly in rural networks. Ironically, it appears that consequent losses appear to increase substantially. This was not an issue until now, but with the newly imposed loss penalties, the financial implications of losses increase have to be carefully assessed by the DNOs. Further work is required on the relative costs and benefits of both voltage control approaches given the upfront costs associated with centralized, active network management. Further research into the incentives given to DNOs to manage losses and connect distributed generation is also warranted.

## VIII. APPENDIX: EXPANSION OF EQUATION 9

Equation 9 provides a continuous approximation of the discrete transition between power factor and voltage control modes:

$$\theta_G = \vartheta_{eq} \Rightarrow \tan^{-1}(Q^G/P^G) = A + K \cdot \tan^{-1}(B \cdot V_G + C)$$

Here

$$A = \theta_{\min} + K \frac{\tan^{-1}[S_1 + S_2]}{(V_{\max} - V_{\text{threshold}}) \cdot \mu_{\text{threshold}}^{\min} \cdot \mu_{\max}^{\min}},$$

$$B = \frac{\tan[(\theta_{\text{threshold}} - A)/K] - \tan[(\theta_{\max} - A)/K]}{V_{\text{threshold}} - V_{\max}},$$

$$C = \tan[(\theta_{\max} - A)/K] - B \cdot V_{\max}, \quad K = K_{\text{steep}} \frac{\theta_{\text{PFC}} - \theta_{\min}}{\pi},$$

$$S_1 = (V_{\max} - V_{\min}) \cdot \mu_{\text{threshold}}^{\min} \cdot \nu_{\max}^{\min},$$

$$S_2 = (V_{\min} - V_{\text{threshold}}) \cdot \mu_{\max}^{\min} \cdot \nu_{\text{threshold}}^{\min},$$

$$\mu_y^x = \sin[(\theta_x - \theta_y)/K], \quad \nu_y^x = \cos[(\theta_x - \theta_y)/K]$$

and  $\theta_{\text{threshold}}$  is the intersection of the smoothed curve with the voltage threshold  $V_{\text{threshold}}$ .  $K_{\text{steep}}$  is a real number marginally greater than 1, which defines the steepness of  $\tan^{-1} \theta$ . The higher the value, the smoother the transition from  $\theta_{\text{PFC}}$  to  $\theta_{\min}$ . A value of 1.01 for  $K_{\text{steep}}$  produces a quite smooth function without significant loss in precision.

## ACKNOWLEDGEMENT

The authors acknowledge the support of the Scottish Funding Council for the Joint Research Institute with the Heriot-Watt University which is a part of the Edinburgh Research Partnership.

## REFERENCES

- [1] C. L. Masters, "Voltage rise: the big issue when connecting embedded generation to long 11kV overhead lines," *Power Engineering Journal*, vol. 16, no. 1, pp. 5-12, Feb. 2002.
- [2] S. N. Liew and G. Strbac, "Maximising penetration of wind generation in existing distribution networks", *IEE Proc. Gener. Transm. Distrib.*, Vol 149, No. 3, May 2002.
- [3] T. Bopp, A. Shafiu, I. Cobelo, I. Chilvers, N. Jenkins, G. Strbac, H. Li and P. Crossley, "Commercial and technical integration of distributed generation into distribution networks", *CIREN, 17th International Conference on Electricity Distribution*, 2003.
- [4] A. Shafiu, T. Bopp, I. Chilvers, G. Strbac, "Active management and protection of distribution networks with distributed generation", *Power Engineering Society General Meeting*, 6-10 June 2004, vol. 1, pp. 1098-1103.
- [5] A.E. Kiprakis and A.R. Wallace; "Maximising Energy Capture from Distributed Generators in Weak Networks", *Proc. Inst. Elect. Eng.-Gen. Transm. Dist.*, vol. 151, no. 5, 2004, pp. 611-618.
- [6] G. P. Harrison and A. R. Wallace, "OPF evaluation of distribution network capacity for the connection of distributed generation", *Proc. Inst. Elect. Eng.-Gen. Transm. Dist.*, vol. 152, no. 1, 2005, pp. 115-122.
- [7] P. N. Vovos, G. P. Harrison, A. R. Wallace and J. W. Bialek, "Optimal Power Flow as a tool for fault level constrained network capacity analysis", *IEEE Trans. Pwr. Sys.*, vol. 20, no. 2, 2005, pp 734-741.
- [8] P. N. Vovos and J. W. Bialek, "Direct incorporation of fault level constraints in optimal power flow as a tool for network capacity analysis", *IEEE Transactions on Power Systems*, vol. 20, no. 4, 2005, pp. 2125-2134.
- [9] T.W. Eberly and R.C. Schaefer, "Voltage versus VAR/power-factor regulation on synchronous generators", *IEEE Trans. Ind. Apps.*, vol. 38, 2002, 1682-1687.
- [10] S. R. Wall, "Performance of inverter interfaced distributed generation", *IEEE/PES Transmission & Distribution Conference & Exposition*, 2001.
- [11] Ofgem, Electricity Distribution Price Control Review, Final Proposals, Office of Gas and Electricity Markets, London, Nov. 2004.
- [12] B. M. Weedy and B. J. Cory, *Electric Power Systems*, 4th Ed. Chichester: Wiley, 1998.
- [13] G. Strbac, N. Jenkins, P. Djapic, M. Hurd and G. Nicholason, 'Benefits of active management', Dept. of Trade and Industry, 2003.

## BIOGRAPHIES



**Panagis N. Vovos** was born in Athens, Greece, on October 23, 1978. He graduated from the Electrical Engineering Dept., University of Patras, Greece in 2002 and his PhD was awarded by the University of Edinburgh in 2005. His special fields of interest include cross-border congestion management, efficient capacity allocation and enhanced OPF.



**Aristides E. Kiprakis** was born in Heraklion, Crete, Greece. He holds a BEng in Electronics from the Technological Education Institute of Crete and a PhD in Electrical Power Engineering from the University of Edinburgh, where he is currently a Research Fellow, working for the Supergen Marine Energy Consortium.. His research interests include modeling and control of distributed generation and renewable energy resources.

Dr. Kiprakis is a member of the Institution of Engineering and Technology, UK.



**Robin Wallace** is Head of the Institute for Energy Systems at the University of Edinburgh. In addition to his research in network integration of distributed generation, he is Co-Director of the UK Energy Research Centre, leads the Engineering and Physical Sciences Research Council's Supergen Marine Energy Consortium and is a Consultant on small hydropower and distributed generation issues.

Professor Wallace is a Fellow of the Institution of Engineering and Technology and a Chartered Engineer.



**Gareth P. Harrison (M'02)** is a Lecturer in Energy Systems in the School of Engineering and Electronics, University of Edinburgh. In addition to his work on integrating distributed generation into electricity networks, he is involved in analysing the impact of climate change on the electricity industry with emphasis on hydropower, marine energy and electricity demand.

Dr. Harrison is a Member of the Institution of Engineering and Technology, UK and a Chartered Engineer.