

PLANNING FOR OPTIMAL ACCOMMODATION OF DISPERSED GENERATION IN DISTRIBUTION NETWORKS

A. Robin WALLACE and Gareth P. HARRISON
The University of Edinburgh - United Kingdom
Robin.Wallace@ed.ac.uk; Gareth.Harrison@ed.ac.uk

SUMMARY

The capacity of dispersed renewable generation will increase significantly in the UK and elsewhere as a result of Government targets and incentives. Its connection at distribution level creates a number of technical problems that for individual connections can be mitigated, albeit at a cost to the developer and network operators. For significant volumes of connections, there is an apparent risk of conflict between connections in that inappropriately sized or located plant could constrain greater development of the network and consequently threaten the achievement of Government renewable energy targets. In this paper, techniques are outlined that provide a means of determining the maximum capacity of generation that may be accommodated within a network. The optimal power flow-based techniques appear to be suited to the task and could provide the basis of planning tools for network operators.

DISPERSED GENERATION

Small-scale dispersed generation (DG) is fast replacing large centralised generation in liberalised electricity markets. The EU Renewables Directive and national incentives such as the UK Renewables Obligation [1] are encouraging the development of renewable energy resources, in particular, wind. These resources are located in areas with low population and load densities and the potential capacities of new plant often means that they will connect to medium or low voltage distribution networks. Historically, the distribution networks in these areas were designed to supply demand that reduced with distance from the transmission system and were operated passively to ensure that the quality of electricity supplied to customers was kept within statutory limits.

Connection of DG can fundamentally alter the operation of distribution networks. Where DG capacity is comparable to or larger than local demand there are likely to be observable impacts on network power flows and voltage regulation [2]. New connections of DG must be evaluated to identify and quantify any adverse impact on the security and quality of local electricity supplies. While a range of options exist to mitigate adverse impacts, under current commercial arrangements the developer will largely bear the financial responsibility for their implementation. The economic implications can make potential schemes less attractive and, in some instances, has been an impediment to the development of renewable energy.

IMPACT OF DISPERSED GENERATION

The presence of dispersed generation can have a number of significant impacts on the operation of the distribution network. Widely documented and described in greater detail elsewhere [2]-[4], they include:

1. Bi-directional power flow and the potential to exceed equipment thermal ratings
2. Reduced voltage regulation and violation of statutory limits on supply quality
3. Increased short circuit contribution and fault levels
4. Altered transient stability
5. Degraded protection operation and co-ordination

The impacts that arise from an individual DG scheme are assessed in detail when the developer makes an application for connection. Distribution Network Operators (DNOs) appraise requests for connection under near-worst case operating conditions to ensure that the quality of supply to their customers will not be adversely affected under all normal DG and network operating scenarios. Typically, network power flow studies are carried out assuming that the DG is operating at maximum capacity, but that local load is at a minimum. These conditions are chosen as they represent the largest reverse power flows and consequently cause the greatest local voltage change which, particularly for rural areas, tends to be the most significant limitation to the capacity of DG that can be connected [3].

ACCOMMODATING DG

There are a number of options open to the DG developer and DNO to reduce adverse network effects arising from a potential DG project and these depend on the initial problem. Where there is the potential to exceed the thermal or fault level rating of equipment then there is generally little option but to replace affected equipment with new plant of higher rating. However, the barrier most frequently met and that which offers most scope for innovative solution is the maintenance of local voltages within statutory limits. The mitigation strategies used currently include:

1. Reduction of primary substation voltage
2. Operation of generator at leading power factor
3. Constraining of export
4. Upgrading conductors
5. Connection at higher voltage

Mitigation techniques 1 to 3 are of an operational nature and have consequent implications for DG revenue or local quality of supply. Measures 4 and 5 can bring considerable capital costs to the DG development, but result in fewer operational restrictions. The present ‘deep charging’ system allows the DNO to insist that the developer finances expenditure necessary to mitigate adverse impacts, as a condition of connection. The changes may add significantly to project capital costs and, particularly for smaller projects, it may render them uneconomic, limiting the penetration of renewable capacity. Alternative ‘shallow charging’ systems are being considered where the DNO finances the necessary network upgrading and collects Distribution Use of System (DUoS) charges from generators [5]. Here the DNO has to consider carefully whether the volume of renewable resource and commitment by developers could properly justify the investment. Proposed alternative means of accommodating DG include active voltage management and more intelligent control of generators [6].

A further risk to the meeting of Government targets can emerge from the current strategy of developing sites on a first come-first served basis. Currently, a developer's rights to network access are guaranteed once the Connection Agreement is signed. With this guarantee instated, subsequent developments in the same area must not impact adversely on the access afforded to previously connected DG. This means that an early and sometimes quite minor connection can prevent development of other larger sites in the same area of the network, effectively ‘sterilising’ areas of the network. If unchecked, this effect can lead to developers rushing to ‘bag capacity’ and guarantee access.

MULTIPLE CONNECTIONS

The current approach of DG appraisal is acceptable for individual connections, where the impact of the generator can be clearly identified and mitigated (at a cost). However, with larger volumes of developments, not only is the assessment of their impact a major task for DNOs but also that there is an increased risk that first-come first-served development will frustrate efforts to meet Government targets.

There is potential for DG plant to deliver benefit to the rural network by reducing losses and providing increased reliability, stability and security of supply. However, to extract these benefits, active management of the network would be required along with commercial benefit for the DNO. Furthermore, more DNOs must become empathetic in their evaluation of network access.

One of the most fundamentally helpful measures for DNOs to issue information to developers regarding the existence, or otherwise, of spare connection capacity [5]. As such, DNOs must be able to quantify the capacity of new generation that may be connected to the distribution network with and without the need for reinforcement.

Recent studies of the transmission network in Scotland have provided a number of locational signals for the development of renewable resources that are contingent on significant investment in the network [7]. They have identified areas where renewable energy could be absorbed by the existing and upgraded transmission network. Not all of the new developments will be deep-connected and most will connect to the sub-transmission or distribution network. Carrying out a similar study on even a relatively small section of the distribution network is extremely intensive and time consuming due to the much greater number of buses and the greater influence of voltage, thermal and fault level restrictions. Effective study of the distribution network therefore required a means of dealing with the multi-dimensional problems and labour intensity.

SIMULATION MANAGER

To this effect, an automated approach has been sought. Evaluation of a number of proprietary power flow software packages found that only a small fraction offered some degree of automation, and most of these required manual preparation of each load flow prior to batch operation.

A solution was developed using the widely respected PSS/E power flow software [8] possessing an internal programming language (IPLAN) that enables dynamic alteration of case parameters. While the necessary data could be entered through dialogue boxes or text files, this manual scheme for data preparation, routine execution and results extraction and analysis remained somewhat time-consuming and error-prone.

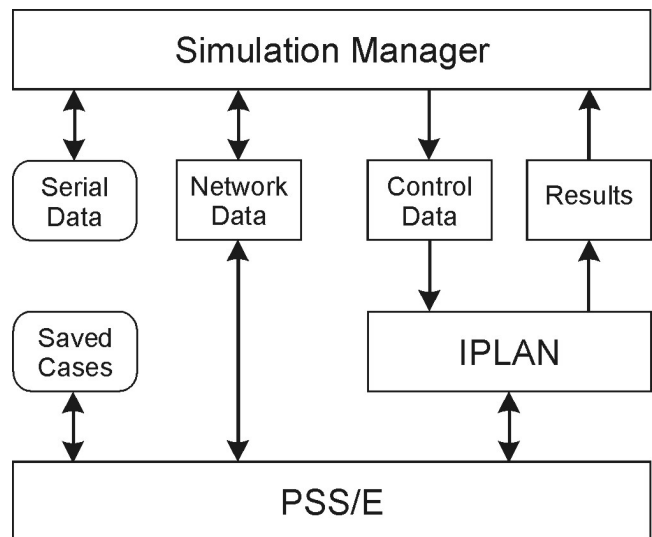

FIGURE 1 – Simulation manager and PSS/E

Significant improvements came though the development of a bespoke Windows user interface that uses the PSS/E package as a power flow engine. It controls the PSS/E package to automatically supply data to it, execute analytical routines and extract results from it in a concise form. The simulation

manager has a number of benefits including effective data management, error removal, integration of non-network-related data and rapid analysis of results. The relationship and data flows between the two packages are shown graphically in Figure 1.

POWER SYSTEM

The system used in this work is a model of part of the UK transmission and distribution network. The 183-bus network covers the voltage range from 400 kV down to 11 kV. Total circuit length is over 10,000 km with around 6,000 and 600 km at 11 and 33 kV, respectively. The network serves a total load of around 100 MVA in a mainly rural setting and the land mass served has extensive potential for on- and offshore wind, mini-hydro and other renewable energy developments. Additionally, over 300 MW of larger centrally-dispatched generation is located in the network. In many respects the DG issues facing the network are quite reflective of the UK as a whole.

In illustrating the application of the simulation manager to the task of determining the maximum penetration of DG within the network, it was deemed to be more effective to relate it to a small section of the overall system model described above. The 20-bus sub-system is presented in Figure 2 and incorporates a section of the 132 kV sub-transmission network (acting as swing bus), the 33 kV network and 11 kV primary sub-stations.

While the planning and operation of the system works on the basis of maintaining the 11 kV system within 4% of nominal voltage, for illustration, variation within the full 6% range allowed by UK statute [9] has been allowed.

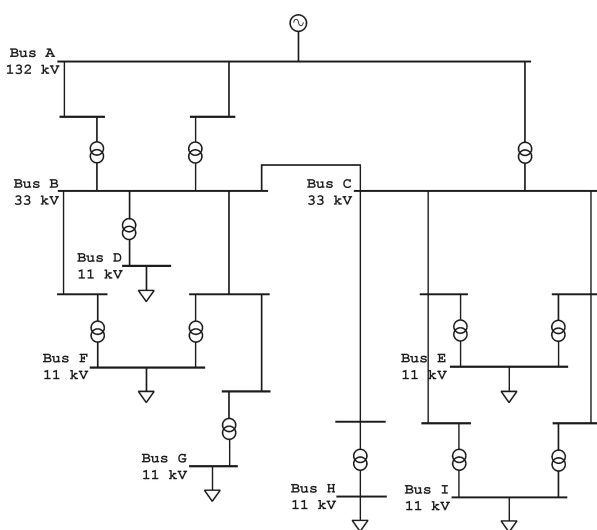

FIGURE 2 – Example sub-system

MAXIMISING DG CAPACITY

Single Bus Injections

The most basic analysis follows the approach of current DG appraisal practice by examining the conditions at individual locations. Routines developed for the simulation manager and PSS/E enabled a location by location appraisal of the possible DG capacity that could be connected subject to the relevant constraints. The routines increase, incrementally, the bus injections from the DG source until there is a constraint violation - this point defines the maximum capacity at that location. Table 1 shows the maximum possible injections at each bus in turn from a synchronous generator operating at a power factor of 0.9 lagging, subject to voltage and thermal constraints. In most cases, the injection is constrained by voltage with the generator bus reaching 1.06 pu. The exception is Bus H where the constraint is the thermal limit on the Bus C – Bus H conductor. As can be seen, there is considerable variation between buses as to the capacity of generation they can absorb.

TABLE 1 – Maximum capacity available at individual locations

	Maximum Injection (MW)	Constraint
Bus D	24.60	Voltage
Bus E	23.51	Voltage
Bus F	14.75	Voltage
Bus G	3.50	Voltage
Bus H	7.49	Thermal
Bus I	6.16	Voltage

Multiple Development

Rather than just connecting one generator at one bus, DG development in resource-rich areas tends to be at adjacent, or nearby, buses across the rural network. While the analysis for individual location is useful in showing the relative sensitivity of buses to power injection, it does not assist in exploring the possible penetration across a network. This is due to the interdependence of buses with, for example a rise in the voltage at one bus also tending to lift the voltage at nearby buses. Given this interdependence and the non-linearity of networks (i.e. super-position is not valid), determination of maximum power injections across multiple buses is rather more complex. Add to that the large number of buses and wide range of generator capacities and the problem becomes very large and computationally intensive. While exhaustive search techniques could be applied to very small systems, a more efficient search algorithm was required for larger ones.

Techniques applied to distribution system optimisation problems include genetic algorithms and tabu search [10]-[11]. Here, Optimal Power Flow (OPF), generally used at transmission level (e.g., minimal fuel cost [12]), is used for

DG capacity maximisation. Ideally, the objective function of the OPF would allow maximisation of the generation capacity at specified locations. However, this is not available with proprietary OPF packages. Also, the generator output maximisation routines generally use PV generator models that are not suitable for fixed power factor DG. These restrictions were overcome using the idea of ‘reverse load-ability’. Here, the PQ generators are modelled as loads and the loads maximised by ‘negative load shedding’. The operation and versatility of the technique is illustrated with a number of examples (1 to 4).

1 – Single Bus Injections. The OPF was firstly tested to confirm that it was able to replicate the results of the individual bus injections (Table 1), by optimising each bus in turn under thermal and voltage constraints. In all cases, the bus injections match the previous values.

2 – Two Buses. The next stage was to determine the optimal addition of capacity at two locations. As Table 1 indicated, Buses F and G, may individually accommodate 14.75 MW and 3.5 MW, respectively. Optimising them jointly, however, only 14.85 MW in total can be added, mainly at Bus F (Table 2). By restricting the capacity connected at bus G (by 2.63 MW), almost 14 MW of capacity may be connected at bus F. Relative to either bus alone this represents an increase in overall capacity and, is achieved by sacrificing generation at individual buses.

TABLE 2 – Optimal capacities at a selection of locations

	G Only (MW)	G and F (MW)	G, F & E (MW)	D to I (MW)
Bus G	3.50	0.87	0.85	0.76
Bus F		13.98	13.19	10.13
Bus E			22.41	19.00
Bus D				18.94
Bus H				2.56
Bus I				1.65
Total	3.50	14.85	36.45	53.04

3 – Three Buses. A similar picture emerges when Bus E is incorporated. The optimal capacity rises to 36.45 MW split 13.19 MW, 0.85 MW and 22.41 MW between Buses F, G, and E. Again, individual capacity is reduced in the pursuit of an increased (21.60 MW) overall maximum capacity (Table 2). The converse is also true with the maximisation of individual sites lowering the total.

4 – 11 kV Buses. Finally, the extension of the optimisation across all six 11 kV buses (D to I) leads to a further increase in capacity. Here, a further 16.6 MW of capacity may be added to the system by reducing the individual contributions at buses E to G (Table 2). The optimal allocation of capacity at each bar reflects the earlier single injection tests with capacity tending to be sited at the more accommodating

locations. This can be seen in Figure 3 which compares the capacity added at each bus for individual bus injections (Table 1) with the optimal solution using OPF. Additionally, it can be seen that for each bus the OPF delivers lower injections and consequently a lower overall capacity of new generation (53 MW).

In addition to showing the results from each of examples 1 to 4, Table 2 shows the progression of optimal capacity with greater numbers of locations. In each case there is a situation where the addition of generation in the network would lead to violations. Furthermore, the benefit can be seen, in terms of increased overall capacity, of the trade-off of potential capacity at less absorbent sites in favour of connecting capacity at more suitable locations. While the system examined here is rather small, the impact of encouraging development in favourable locations is clear. Across a larger or regional system the potential to identify enhanced DG development may be significant. The technique offers a means by which DNOs can examine their networks for spare capacity for the purpose of providing information to developers regarding the best and worst places to connect DG.

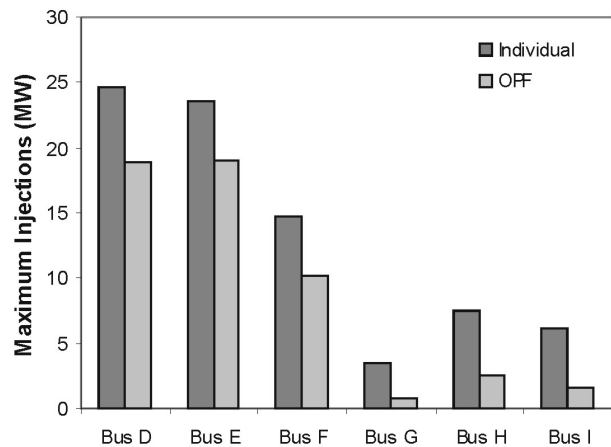

FIGURE 3 – Individual bus injection versus OPF

Maximising Integration

It is worth considering at this stage whether either of the two techniques illustrated are representative of the nature of DG development. Clearly, single injection delivers the maximum capacity at individual locations, whilst the OPF techniques determines the maximum simultaneous new capacity across all, or specified, locations. Neither of these is truly representative given that new DG capacity will be added sequentially over time and that both analyses ignore the impact of prior development. Two extreme situations may be identified:

1. Guaranteed access for existing capacity, with danger of network sterilisation, or
2. Permit maximum new capacity to connect, potentially stranding existing assets.

The examination of such situations requires the capability to develop and analyse scenarios of future DG development. The OPF techniques facilitate this. Consider the development of three buses: F (at 11 kV) and B and C (both at 33 kV). OPF analysis of a similar nature to examples 1 to 4 implies an optimal capacity of 103.1 MW. This would be added entirely at the 33 kV level (split 74.8 MW and 28.3 MW between buses B and C, respectively) with no allocation for 11 kV. The allocation reflects the relatively smaller voltage rise effect at higher voltages.

In the case where a DG has been guaranteed access for a 10 MW generator at bus F, the determination of available capacity must take this into account. The addition results in new capacity at 33 kV (as before) but with a vastly reduced volume. As Table 3 shows, together with the 10 MW DG at bus F, the total allowable capacity across the three buses is just over 59 MW. Hence, the prior addition of a 10 MW generator in a non-optimal location reduces the total available capacity by almost 44 MW, providing a stark illustration of network sterilisation.

At the other extreme, where a 10 MW DG plant connects to bus F with no access guarantee, this plant is ignored in the analysis and the optimal capacity remains as originally determined above (Table 1). If generation of the relevant capacities were to be connected at the higher voltage buses, the DG at bus F would be likely to be constrained off, providing an example of the stranding of DG assets.

TABLE 3 – Capacity under different planning scenarios

	No access guarantee (MW)	Bus F access guarantee (MW)
Bus B optimal capacity	74.75	18.31
Bus C optimal capacity	28.31	30.90
Bus F optimal capacity	0.00	0.0
Access at Bus F	-----	10.0
Total capacity	103.06	59.21

These examples offer relatively simple and extreme development scenarios. Planning for connections across a wider number of locations creates a much larger set of possible scenarios. Despite this, the process of determining available capacities will remain the same, with the simulation manager providing the necessary automation to reduce the burden of the task.

DISCUSSION

The OPF-based techniques presented here have the potential to be a valuable addition to the planning capabilities of DNOs by providing a rapid, adaptable and objective means of examining the connection of DG to their networks. This will

be of benefit in providing information to developers regarding the best and worst places to connect DG and, further, will assist with network development and planning.

Clearly, the examples used here are very simple and have employed a number of simplifying assumptions. Firstly, the transformers have fixed taps thus avoiding the inclusion of tap settings in the optimisation. Secondly, the only traditional generator on the system is the swing bus, hence the effect of generator reactive power limits are ignored. Initial application of the OPF techniques to the larger system, incorporating traditional generation, presented practical difficulties for the OPF. However, work is underway to resolve these issues.

The small section of a real network is used successfully to illustrate many of the issues surrounding the connection of DG. Despite the simple nature of the examples a number of observations can be made. Firstly, inappropriately sized or located connections at lower voltages limit subsequent development and the overall capacity accommodated. Secondly, inappropriate connections at higher voltages could strand existing assets and reduce overall capacity. Overall, careful siting of DG will allow the maximum accommodation of such plant and facilitate the development of renewable energy in pursuit of Government targets.

CONCLUSIONS

The capacity of dispersed renewable generation will increase significantly in the UK and elsewhere. Its connection at distribution level creates a number of technical problems that for individual connections can be mitigated, albeit at a cost to the developer and DNO.

The current system of appraising DG connections on a case-by-case basis, risks the sterilisation of distribution networks through the inappropriate sizing or location of plant and could hamper efforts to achieve Government targets for renewable energy.

Development of bespoke software to control and interface with an industry-standard power flow package has assisted greatly in developing analytical techniques to investigate these issues. The ability to determine maximum capacity at a given location, and with the use of OPF techniques, over a network provides a means of planning and managing DG connections whilst limiting the risk of network sterilisation.

ACKNOWLEDGEMENTS

The authors acknowledge, with gratitude, the support provided by the UK Engineering and Physical Sciences Research Council (research grant number GR/N04744) and Scottish Power plc. They are grateful also for the assistance of staff at Power Technologies Ltd.

REFERENCES

- [1] Department of Trade and Industry, 2002, *The Renewables Obligation Order 2002*, Stationary Office.
- [2] A.R. Wallace, 1999, "Protection of embedded generation schemes", *IEE Colloquium on Protection and Connection of Renewable Energy Systems*, 1/1-1/5.
- [3] C.L. Masters, 2002, "Voltage rise: the big issue when connecting embedded generation to long 11kV overhead lines", *Power Engineering Journal*, vol. 16, no. 1, 5-12.
- [4] N. Jenkins, R. Allan, P. Crossley, D. Kirschen and G. Strbac, 2000, *Embedded Generation*, IEE, London.
- [5] Department of Trade and Industry, 2001, *Embedded Generator Working Group Report into Network Access Issues*.
- [6] A.E. Kiprakis and A.R. Wallace, 2003, "Hybrid Control of Distributed Generators Connected to Weak Rural Networks to Mitigate Voltage Variation", *CIREN 2003*, 12-15 May, Barcelona, Spain.
- [7] Scottish Executive, 2001, *Impact of Renewable Generation on the Electrical Transmission Network in Scotland*, Edinburgh.
- [8] Power Technologies, Inc., 2000, *PSS/E 27 Program Application Guide*, Schenectady, New York.
- [9] Department of Trade and Industry, 1994, *The Electricity Supply (Amendment) Regulations 1994*, Stationary Office.
- [10] G. Celli and F. Pilo, 2001, "Optimal distributed generation allocation in MV distribution networks", 22nd IEEE PES International Conference on Power Industry Computer Applications PICA 2001, 20-24 May, Sydney, Australia, 81-86.
- [11] K. Nara and Y.H. Song, 2002, "Modern heuristics application to distribution system optimization", IEEE PES Winter Meeting, 826-832
- [12] M. Huneault and F.D. Galiana, 1991, "A survey of the optimal power flow literature", *IEEE Transactions on Power Systems*, vol. 6, no. 2, 762-770.